

## MULTI MONT SELLA

Flexible Claw Coupling

[www.reich-kupplungen.com](http://www.reich-kupplungen.com)



SIMPLY **POWERFUL.**





## D2C – Designed to Customer

The guiding principle of Designed to Customer is the recipe for success behind REICH. In addition to the catalog products, we supply our customers with couplings developed to their specific requirements.

The designs are mainly based on modular components to provide effective and efficient customer solutions.

The special nature of our close cooperation with our partners ranges from; consulting, development, design, manufacture and integration to existing environments, to customer-specific production, logistics concepts and after-sales service - worldwide.

This customer-oriented concept applies to both standard products and production in small batch sizes.

The company policy at REICH embraces, first and foremost, principles such as customer satisfaction, flexibility, quality, prompt delivery and adaptability to the requirements of our customers.

REICH provides you with not only a coupling, but a solution:

Designed to Customer – SIMPLY **POWERFUL**.

**D2C**  
Designed to Customer





# MULTI MONT SELLA

## Contents

## Coupling Information

- 04** General Technical Description

---

  - 05** Advantages

---

  - 06** Standard Types

---

  - 08** Special Types

---

  - 09** General Technical Data

---

  - 14** Materials

---

  - 15** Flexible Coupling Elements

---

  - 16** Selection of the Coupling Size

---

  - 17** Service Factors

---

  - 18** Assignment of the load classification factors to the type of driven machine

---

  - 19** Assignment to IEC standard motors

---

  - 38** Weights and moments of inertia

---

  - 42** Data Required for Coupling Size Selection
- 03/2020

## Dimension tables

- 20** Type MMS-T...W - shaft coupling with taper bush

---

- 22** Type MMS...W - shaft coupling

---

- 24** Type MMS...F1 - flange coupling

---

- 26** Type MMS...T - separable flange coupling

---

- 28** Type MMS...WBS - brake disc coupling

---

- 30** Type MMS...TBS - brake disc coupling

---

- 32** Type MMS...WBT - brake drum coupling

---

- 34** Type MMS...TBT - brake drum coupling

---

- 36** Type MMS...F1 BT - brake drum coupling

# MULTI MONT SELLA

## General technical description

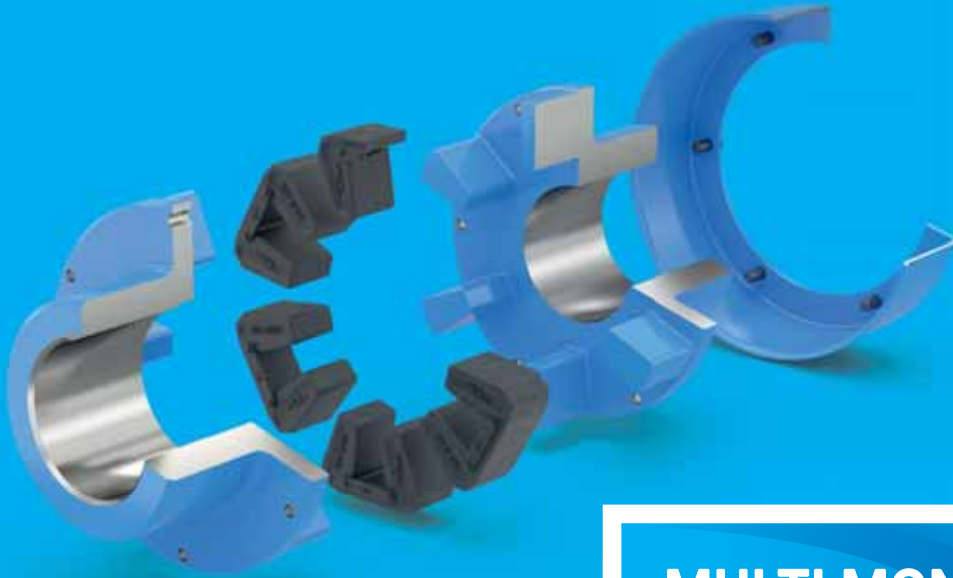

## MULTI MONT SELLA W

Nominal torques from  
550 lb-in to 8 850 700 lb-in (63 Nm to 1 000 000 Nm)

## MULTI MONT SELLA Flexible Claw Coupling

The torsionally flexible MULTI MONT SELLA couplings (abbreviation: MMS) have been built in series since 1958. This pluggable claw coupling, successfully proven over a number of decades, has been continually updated to meet technical developments and cover a torque range from 550 lb-in to 8 850 700 lb-in (63 Nm to 1 000 000 Nm).

The MULTI MONT SELLA product line offers a large variety of different types so that a suitable coupling is available for almost every type of power transmission requirement.

For sizes up to and including MMS 63 the coupling consists of a split toothed ring which has the single rubber dampers attached to an external belt. In addition 6 saddle elements are used each with two rubber dampers attached to an external belt.

The coupling is fitted with a separately screwed-on retaining cap which encloses the periphery of the rubber elements. This screwed connection is not involved in torque transmission. The release and retraction of this retaining cap enables simple radial element exchange without axially shifting coupled machine parts.

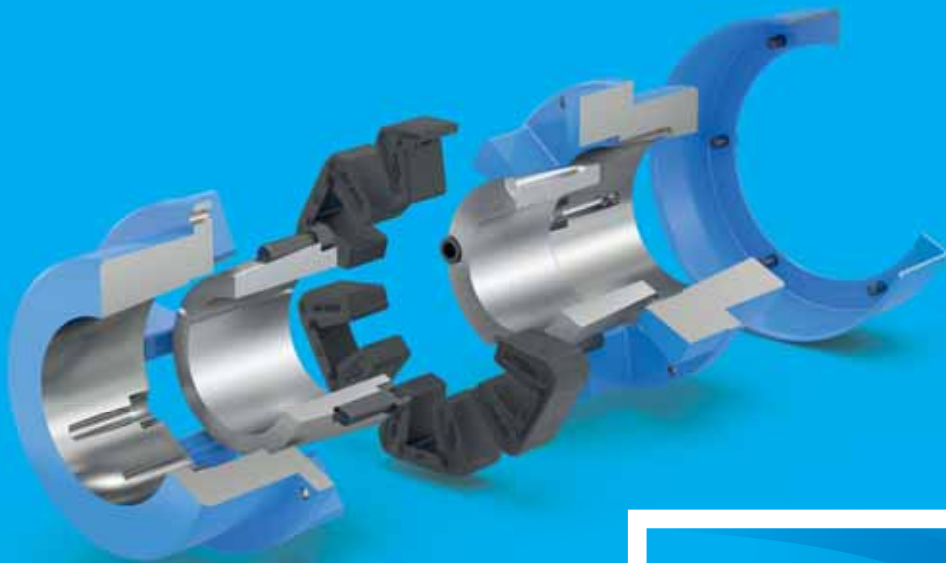

## MULTI MONT SELLA T

Nominal torques from  
2200 lb-in to 1380 00 lb-in (250 Nm to 15 600 Nm)

## MULTI MONT SELLA

### Advantages

#### Salient features and advantages of MULTI MONT SELLA claw couplings:

- Compensate axial-, radial- and angular misalignments
- Damping shocks and vibrations
- Are fail-safe and withstand high overloads
- Well suited as plug-in type couplings ensuring ease of assembly and alignment
- Allow prompt and easy radial change of the flexible elements by sliding back the retaining cap
- Maintenance-free
- Customizable for almost every type of mounting situation
- Easy and simple assembly of the shaft connections thanks to taper bushes
- ATEX 

# MULTI MONT SELLA

## Standard Types

Type MMS-T...W



### Shaft coupling with taper bush

Equipped with a taper bush as a connection element to the shaft. The taper bush is bolted in place in the coupling hub so that a shrink-fit connection free from backlash is established between the coupling hub and the shaft after assembly. The separately bolted on retaining cap allows changing of flexible elements with no need for axial movement of either of the coupling hubs.

Type MMS...W

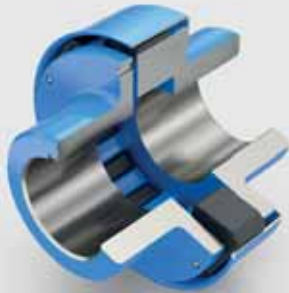

### Shaft coupling



Standard version for connecting two shafts.

The separately bolted on retaining cap allows changing of flexible elements with no need for axial movement of either of the coupling hubs.

Type MMS...F1



### Flange coupling



For flange-mounting to discs and flywheels.

The separately bolted on retaining cap allows changing of flexible elements with no need for axial movement of either of the coupling hubs. Different mounting options are available by using intermediate flanges.

Type MMS...T



### Separable flange coupling



This version allows radial assembly of the coupled machines with no need for their axial movement. The separately bolted on retaining cap allows changing of flexible elements with no need for axial movement of either of the coupling hubs.



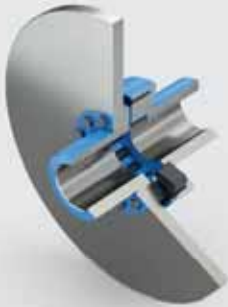

### Brake disc coupling

for brake calipers.

For higher requirements, e.g. for control-optimized drives, backlash free versions are available on request. The separately bolted on retaining cap allows changing of flexible elements with no need for axial movement of either of the coupling hubs.

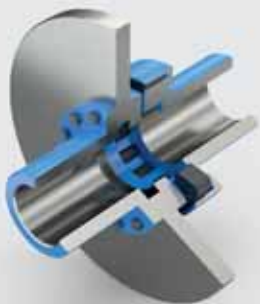

### Brake disc coupling

The TBS type allows radial removal of the brake disc with no need for axial movement of the coupling hubs. The flexible elements can also be easily fitted and removed radially with no need for axial movement of the coupled machines after the retaining cap has been released and withdrawn. For higher requirements, e.g. for control-optimized drives, backlash free versions are available on request. The separately bolted on retaining cap allows changing of flexible elements with no need for axial movement of either of the coupling hubs.



### Brake drum coupling

for external shoe brakes. Brake drum main dimensions in line with DIN 15431. Thanks to the optional mounting facility of the brake drum, the dimension  $L_7$  or  $L_9$  can be selected. For higher requirements, e.g. for control-optimized drives, backlash free versions are available on request. The separately bolted on retaining cap allows changing of flexible elements with no need for axial movement of either of the coupling hubs.



### Brake drum coupling

Thanks to the optional mounting facility of the brake drum, the dimension  $L_7$  or  $L_9$  can be selected. For higher requirements, e.g. for control-optimized drives, backlash free versions are available on request. The separately bolted on retaining cap allows changing of flexible elements with no need for axial movement of either of the coupling hubs. The flexible elements can be easily fitted and removed radially with no need for axial movement of the coupled machines after the retaining cap has been released and withdrawn.

# MULTI MONT SELLA

## Special types

Double flange coupling

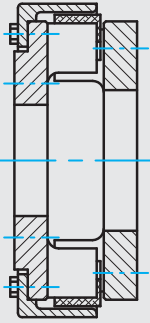

Coupling with spacer

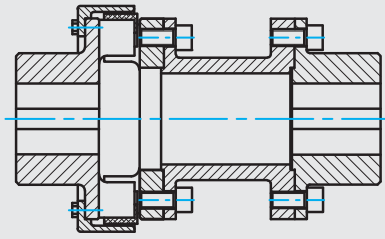

Clutch

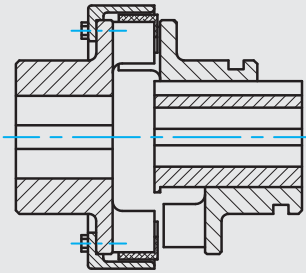

Version with shrink disc

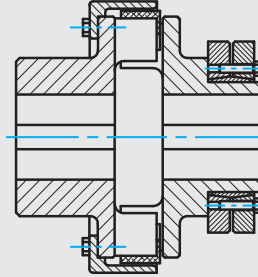

Combination coupling:  
for connection with a  
free-wheeling device

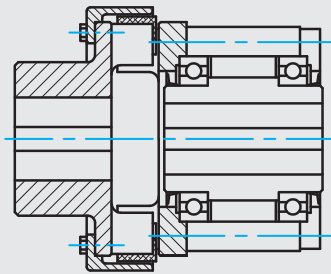

Combination coupling:  
for connection with a  
torque limiter

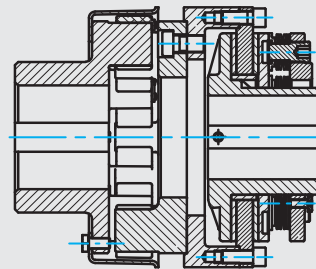



Brake disc-/  
brake drum coupling

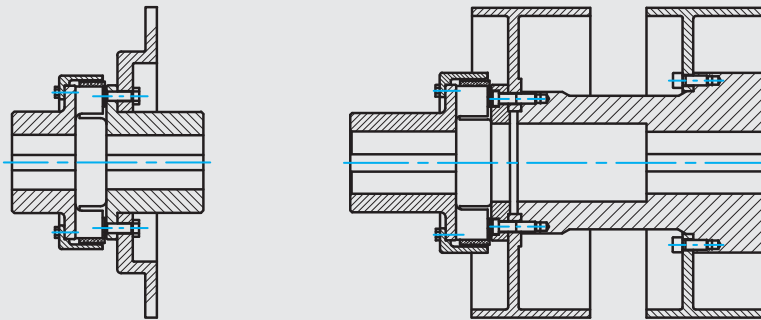

Type MMD...W

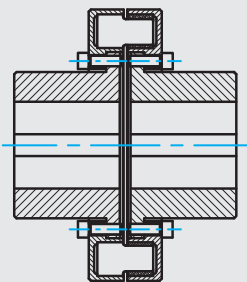

Type MMS-HS

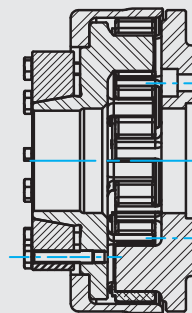

intermediate shaft in  
combination with a tooth  
gear coupling

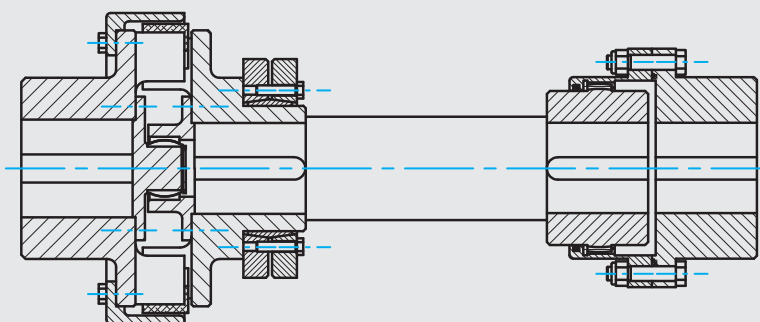

# MULTI MONT SELLA

## General Technical Data

### Standard Types

The torques specified for  $T_{KN}$  or  $T_{Kmax}$  correspond to the definition for 'Flexible shaft couplings DIN 740 Part 2' and apply to the standard designs.

Coupling size	Element version	Nominal torque $T_{KN}$ [Nm]	Continuous vibratory torque $T_{KW}$ (10 Hz) [Nm]	Maximum torque $T_{Kmax}$ [Nm]	Dynamic torsional stiffness				Rel. damping $\Psi$ -	Max. speed*) $n_{max}$ [rpm]	Max. shaft displacement		
					$C_{T\ dyn}$ [ $10^3$ Nm/rad]						$\Delta K_a$ [mm]	$\Delta K_r$ [mm]	$\Delta K_u$ [mm]
					0.25 $T_{KN}$	0.5 $T_{KN}$	0.75 $T_{KN}$	1.0 $T_{KN}$					
MMS 6.3	SN	63	30	189	0.8	1	3	6	1.8	9000	1.0	0.5	1.0
	UN	80			2	3	5	8	2.0				
	UD		2		3	4	5	1.3					
MMS 10	SN	100	50	300	1.5	2	5	10	1.8	7100	1.0	0.6	1.2
	UN	125			3	5	8	12	2.0				
	UD		3		5	6	8	1.3					
MMS 16	SN	160	80	480	2	3	7	15	1.8	6300	1.0	0.6	1.3
	UN	200			4	7	12	19	2.0				
	UD		5		8	10	13	1.3					
MMS 25	SN	250	130	750	3.5	5	11	23	1.8	7800	1.0	0.7	1.4
	UN	315			7	12	19	30	2.0				
	UD		9		12	15	20	1.3					
MMS 40	SN	400	210	1200	5	8	18	37	1.8	6800	1.2	0.7	1.5
	UN	500			11	19	30	48	2.0				
	UD		14		19	24	32	1.3					
MMS 63	SN	630	330	1890	7	10	25	60	1.8	6050	1.2	0.8	1.6
	UN	790			17	29	48	75	2.0				
	UD		22		30	38	51	1.3					
MMS 100	SN	1250	530	3000	15	25	55	120	1.8	5400	1.2	0.9	1.7
	UN	1560			35	58	94	150	2.0				
	UD		43		59	75	100	1.3					
MMS 160	SN	2000	840	4800	25	35	90	190	1.8	4750	1.5	1.0	1.8
	UN	2500			55	93	151	239	2.0				
	UD		69		95	120	161	1.3					
MMS 250	SN	3000	1300	7500	35	55	130	280	1.8	4200	1.5	1.2	2.0
	UN	3750			83	140	227	359	2.0				
	UD		115		140	180	250	1.3					
MMS 400	SN	5000	2100	12000	50	70	200	500	1.8	3650	1.5	1.4	2.2
	UN	6250			120	210	440	800	2.0				
	UD		170		230	330	480	1.3					

# METRIC DIMENSIONS



Coupling size	Element version	Nominal torque $T_{KN}$ [Nm]	Continuous vibratory torque $T_{KW}$ (10 Hz) [Nm]	Maximum torque $T_{Kmax}$ [Nm]	Dynamic torsional stiffness				Rel. damping $\Psi$ -	Max. speed <sup>*)</sup> $n_{max}$ [rpm]	Max. shaft displacement		
					$C_{T\ dyn}$ [ $10^3$ Nm/rad]						$\Delta K_a$ [mm]	$\Delta K_r$ [mm]	$\Delta K_u$ [mm]
					0.25 $T_{KN}$	0.5 $T_{KN}$	0.75 $T_{KN}$	1.0 $T_{KN}$					
MMS 630	SN	7500	3300	18900	120	170	380	700	1.8	3200	1.5	1.5	2.4
	UN	9400			207	350	566	898	2.0				
	UD		4150		257	356	452	603	1.3				
MMS 1000	SN	12500	5000	30000	230	280	600	1100	1.8	2800	2.0	1.6	2.6
	UN	15600			350	630	910	1450	2.0				
	UD		6250		450	600	750	1000	1.3				
MMS 1600	SN	20000	8400	48000	290	410	950	1900	1.8	2450	2.0	1.8	2.8
	UN	25000			650	950	1380	1950	2.0				
	UD		10500		685	948	1205	1607	1.3				
MMS 2500	SN	30000	12000	75000	460	600	1400	2800	1.8	2200	2.0	1.8	2.8
	UN	37500			1150	1650	2360	3400	2.0				
	UD		15000		1028	1423	1807	2411	1.3				
MMS 4000	SN	40000	12000	120000	600	1100	1900	3500	1.8	1900	2.5	2.0	2.5
MMS 6300	SN	63000	19000	189000	950	1700	3300	5500	1.8	1650	3.0	2.5	3.0
MMS 10000	SN	100000	30000	300000	1500	2700	5200	8800	1.8	1450	3.5	2.5	3.5
MMS 16000	SN	160000	48000	480000	2300	3000	7500	15000	1.8	1250	4.0	2.0	4.0
MMS 25000	SN	250000	75000	750000	4500	5000	12000	25000	1.8	1100	5.0	2.5	4.5
MMS 40000	SN	400000	120000	1200000	5500	8000	18000	38000	1.8	900	6.0	2.5	5.0
MMS 63000	SN	630000	200000	1890000	on request				1.8	850	7.0	3.0	5.0
MMS 100000	SN	1000000	300000	3000000	on request				1.8	750	8.0	3.0	5.0

**i** \*) max. speeds refer to standard couplings... W, ... F1, ... T made of gray cast iron. higher rotational speeds can be obtained with other materials

## Permissible rotational speeds

The listed maximum speeds only relate to the actual coupling components. For couplings in combination with brake drums and brake discs the following permissible speeds  $n_{max}$  in rpm listed in the table apply.

Diameter BT/BS	BT/BS	[mm]	200	250	315	400	500	630	710	800	1000
Brake drum BT	BT $n_{max}$	[rpm]	5250	4200	3300	2600	2100	1650	1450	-	-
Brake disc BS	BS $n_{max}$	[rpm]	7000	6000	4800	3800	3000	2400	2150	1900	1500

# MULTI MONT SELLA

## General Technical Data

### Standard Types

The torques specified for  $T_{KN}$  or  $T_{Kmax}$  correspond to the definition for 'Flexible shaft couplings DIN 740 Part 2' and apply to the standard types.

Coupling size	Element version	Nominal torque $T_{KN}$ [lb-in]	Continuous vibratory torque $T_{KW}$ (10 Hz) [lb-in]	Maximum torque $T_{Kmax}$ [lb-in]	Dynamic torsional stiffness				Rel. damping $\Psi$ -	Max. speed <sup>*)</sup> $n_{max}$ [rpm]	Max. shaft displacement		
					$C_{T\ dyn}$ [10 <sup>3</sup> lb-in/rad]						$\Delta K_a$ [in]	$\Delta K_r$ [in]	$\Delta K_u$ [in]
					0.25 $T_{KN}$	0.5 $T_{KN}$	0.75 $T_{KN}$	1.0 $T_{KN}$					
MMS 6.3	SN	558	266	1673	7.1	9	9	9	1.8	9000	0.039	0.020	0.039
	UN	708			17.7	26.6	26.6	26.6	2.0				
	UD		354		17.7	26.6	26.6	26.6	1.3				
MMS 10	SN	885	443	2655	13.3	17.7	17.7	17.7	1.8	7100	0.039	0.024	0.047
	UN	1106			26.6	44.3	44.3	44.3	2.0				
	UD		575		26.6	44.3	44.3	44.3	1.3				
MMS 16	SN	1416	708	4248	17.7	26.6	26.6	26.6	1.8	6300	0.039	0.024	0.051
	UN	1770			35.4	62.0	62.0	62.0	2.0				
	UD		885		44.3	70.8	70.8	70.8	1.3				
MMS 25	SN	2213	1151	6638	31.0	44.3	44.3	44.3	1.8	7800	0.039	0.028	0.055
	UN	2788			62.0	106.2	106.2	106.2	2.0				
	UD		1416		79.7	106.2	106.2	106.2	1.3				
MMS 40	SN	3540	1859	10621	44.3	70.8	70.8	70.8	1.8	6800	0.047	0.028	0.059
	UN	4425			97.4	168.2	168.2	168.2	2.0				
	UD		2301		123.9	168.2	168.2	168.2	1.3				
MMS 63	SN	5576	2921	16728	62.0	88.5	88.5	88.5	1.8	6050	0.047	0.031	0.063
	UN	6992			150.5	256.7	256.7	256.7	2.0				
	UD		3540		194.7	265.5	265.5	265.5	1.3				
MMS 100	SN	11063	4691	26552	132.8	221.3	221.3	221.3	1.8	5400	0.047	0.035	0.067
	UN	13807			309.8	513.3	513.3	513.3	2.0				
	UD		5753		380.6	522.2	522.2	522.2	1.3				
MMS 160	SN	17701	7435	42484	221.3	309.8	309.8	309.8	1.8	4750	0.059	0.039	0.071
	UN	22127			486.8	823.1	823.1	823.1	2.0				
	UD		9293		610.7	840.8	840.8	840.8	1.3				
MMS 250	SN	26552	11506	66381	309.8	486.8	486.8	486.8	1.8	4200	0.059	0.047	0.079
	UN	33190			734.6	1239.1	1239.1	1239.1	2.0				
	UD		14161		1017.3	1239.1	1239.1	1239.1	1.3				
MMS 400	SN	44254	18587	106209	442.5	619.6	619.6	619.6	1.8	3650	0.059	0.055	0.087
	UN	55317			1062.1	1858.7	1858.7	1858.7	2.0				
	UD		23012		1504.6	2035.7	2035.7	2035.7	1.3				



# INCH DIMENSIONS



Coupling size	Element version	Nominal torque	Continuous vibratory torque	Maximum torque	Dynamic torsional stiffness				Rel. damping	Max. speed <sup>*)</sup>	Max. shaft displacement		
		$T_{KN}$	$T_{KW}$ (10 Hz)	$T_{Kmax}$	$C_{T\ dyn}$ [ $10^3$ lb-in/rad]				$\Psi$	$n_{max}$	$\Delta K_a$	$\Delta K_r$	$\Delta K_u$
		[lb-in]	[lb-in]	[lb-in]	0.25 $T_{KN}$	0.5 $T_{KN}$	0.75 $T_{KN}$	1.0 $T_{KN}$	-	[rpm]	[in]	[in]	[in]
MMS 630	SN	66381	29207	167279	1062.1	1504.6	3363.3	6195.5	1.8	3200	0.059	0.059	0.094
	UN	83197			1832.1	3097.8	5009.5	7945.0	2.0				
	UD	83197	36731		2274.6	3150.9	4000.5	5337.0	1.3				
MMS 1000	SN	110634	44254	265522	2035.7	2478.2	5310.4	9735.8	1.8	2800	0.079	0.063	0.102
	UN	138072			3097.8	5576.0	8054.2	12833.6	2.0				
	UD	138072	55317		3982.8	5310.4	6638	8850.7	1.3				
MMS 1600	SN	177015	74346	424836	2566.7	3628.8	8408	16816.4	1.8	2450	0.079	0.071	0.110
	UN	221269			5753.0	8408.2	12214.0	17256.0	2.0				
	UD	221269	92933		6062.8	8390.5	10665.1	14223.1	1.3				
MMS 2500	SN	265530	106209	663825	4071.3	5310.4	12391.0	24782.1	1.8	2200	0.078	0.070	0.109
	UN	331903			10178.4	14603.7	20887.8	30092.5	2.0				
	UD	331903	132761		9098.6	12594.6	15993.3	21339.1	1.3				
MMS 4000	SN	354030	106209	1062089	5310.4	9735.8	16816.4	30977.6	1.8	1900	0.098	0.079	0.098
MMS 6300	SN	557597	168164	1672791	8408.2	15046.3	29207.5	48679.1	1.8	1650	0.118	0.098	0.118
MMS 10000	SN	885075	265522	2655224	13276.1	23897.0	46023.9	77886.6	1.8	1450	0.138	0.098	0.138
MMS 16000	SN	1416199	424836	4248358	20356.7	26552.2	66380.6	132761.2	1.8	1250	0.157	0.079	0.157
MMS 25000	SN	2212686	663806	6638059	39828.4	44253.7	106209.0	221268.7	1.8	1100	0.197	0.098	0.177
MMS 40000	SN	3540298	1062090	10620895	48679.1	70806.0	159313.4	336328.3	1.8	900	0.236	0.098	0.197
MMS 63000	SN	5575970	1770149	16727910	on request				1.8	850	1.8	0.118	0.197
MMS 100000	SN	8850746	26552237	26552237					1.8	750	1.8	0.118	0.197

**i** \*) max. speeds refer to standard couplings... W, ... F1, ... T made of gray cast iron. higher rotational speeds can be obtained with other materials

## Permissible rotational speeds

The listed maximum speeds only relate to the actual coupling components. For couplings in combination with brake drums and brake discs the following permissible speeds  $n_{max}$  in rpm listed in the table apply.

Diameter BT/BS	BT/BS	[in]	7.874	9.843	12.402	15.748	19.685	24.803	27.953	31.496	39.370
Brake drum BT	BT $n_{max}$	[rpm]	5250	4200	3300	2600	2100	1650	1450	-	-
Brake disc BS	BS $n_{max}$	[rpm]	7000	6000	4800	3800	3000	2400	2150	1900	1500

# MULTI MONT SELLA

## Materials



### Material Overview

Component	Designation of the coupling components		Material
1 f/h	Hub	Size MMS-T 25 - 1000	0.6025 (EN-GJL-250)
1/1a		Size MMS 6.3 - 16	0.6025 (EN-GJL-250)
		Size MMS 25 - 63 000	0.7040 (EN-GJS-400-15)
		Size MMS 100 000	1.0558 (GE300)
2	Retaining cap	Size MMS 10 - 16	Polyamide
		Size MMS 6,3/25 - 40	Sheet steel
		Size MMS 63 - 400	0.7040 (EN-GJS-400-15)/Sheet steel
		Size MMS 630 - 2 500	0.7040 (EN-GJS-400-15)
		Size MMS 4 000 - 100 000	1.0577 (S355J2)
3	Flexible coupling element		see adjacent table (p.13)
4	Flange	MMS ... T, ... F1	0.7040 (EN-GJS-400-15)
6/6a	Separable flange hub	MMS ... T, ... TBS, ... TBT	1.0577 (S355J2)/1.0503 (C 45)
10	Brake disc	-	1.0577 (S355J2)/1.0503 (C 45)
11	Brake drum up to Ø 315 mm for F1 BT		0.7050 (EN-GJS-500-7)
	Brake drum up to Ø 315 mm for WBT		1.0577 (S355J2)/1.0503 (C 45)
	Brake drum from Ø 315 mm for WBT and TBT		0.7050 (EN-GJS-500-7)

**i** Part no. can be found in the drawings of the individual types

Coupling hubs in spheroidal cast iron are used as standard. If special material specifications exist, other materials are available as an option

### Technical Note

The technical data applies only to the complete coupling or the corresponding coupling elements. It is the customer's/user's responsibility to ensure there are no inadmissible loads acting on any of the components. In particular, existing connections, e.g. bolted connections, must be checked with regard to the torques to be transmitted. If necessary, further measures, such as additional reinforcement with pins, may be necessary. It is the customer's/user's responsibility to make sure the dimensioning of the shaft and keyed or other connection, e.g. shrinking or clamping connection, is correct.

All components that can rust are protected against corrosion as standard.



REICH have an extensive range of couplings and coupling systems to cover nearly every drive configuration. Customized solutions can be developed and manufactured even in small batches or as prototypes. In addition calculation programs are available for all necessary dimensioning.

## Conversion table

1 [°F]	9/5 °C + 32	1 [°C]	5/9 (°F - 32)
1 [lb] (avdp)	0.454 [kg]	1 [kg]	2.205 [lb] (avdp)
1 [in]	25.4 [mm]	1 [mm]	0.039 [in]
1 [lb-in]	0.113 [Nm]	1 [Nm]	8.851 [lb-in]
1 [lb-in/rad]	0.113 [Nm/rad]	1 [Nm/rad]	8.851 [lb-in/rad]
1 [lb-in <sup>2</sup> ]	0.000292 [kgm <sup>2</sup> ]	1 [kgm <sup>2</sup> ]	3417.17 [lb-in <sup>2</sup> ]
1 psi	0.069 bar	1 bar	14.5 psi

## Flexible coupling element

Type of element	size	Quantity per coupling
MMS toothed ring	MMS 6.3 - 63	1
MMS saddle elements	MMS 100 - 63 000	6
MMS saddle elements-pair	MMS 100 000	8 x 2

Material designation	Code	Permissible temperature range		Feature	ATEX certified
			shortly		
Natural/synthetic caoutchouc Hardness range: 75 - 80° Shore A	SN	-40 °C to 80 °C -40 °F to 176 °F	90 °C 194 °F	excellent abrasion resistance	
Natural/synthetic caoutchouc Hardness range: 80 - 90° Shore A	UN	-40 °C to 80 °C -40 °F to 176 °F	90 °C 194 °F	excellent abrasion resistance, increased torque capacity	
Polyurethane (PUR) Hardness range: 90 - 95° Shore A	UD	-30 °C to 120 °C -22 °F to 248 °F	130 °C 266 °F	high strength; very good abrasion resistance; high temperature resistance; resistant to mineral oil and motor fuels	
Synthetic caoutchouc (NBR) Hardness range: 73 - 78° Shore A	SP	-40 °C to 100 °C -40 °F to 212 °F	120 °C 248 °F	resistant to mineral oil and motor fuels	

**i** General technical data for MULTI MONT SELLA couplings with NBR elements on request. Other rubber materials and other shore hardnesses can also be supplied on request

## Balancing

All MULTI MONT SELLA couplings are of balancing quality G 16 for  $n = 1500$  rpm acc. to DIN ISO 21940 as a standard sufficient for normal speed ranges. Should a higher balancing quality be required, please specify the speed and the desired balancing quality when ordering.

# MULTI MONT SELLA

## Selection of the coupling size

The coupling size should be selected to ensure that the permissible coupling load is not exceeded in any operating condition encountered. For drives which are not subject to periodically recurring fatigue torques the coupling design may be selected based on the driving torque with reference to the corresponding service factors.

For drives with combustion engines or prime movers which are subject to periodically recurring vibratory torques, the final selection of the coupling should be verified by a full torsional vibration analysis which will be conducted by us on request.

### In selecting the coupling size the following should be satisfied:

1. The **nominal torque of the coupling**  $T_{KN}$  must be taken into account at every temperature and operating load of the coupling, while observing the service factors  $S$  (e.g. temperature factor  $S_t$ ) shall be at least equal to the maximum nominal torque on the drive side  $T_{AN}$ ; the temperature in the immediate vicinity of the coupling must be taken into account.

$$T_{KN} \geq T_{AN} \cdot S_m \cdot S_t \cdot S_z$$

2. The **nominal torque on the drive side**  $T_{AN}$  is calculated with the driving power  $P_{AN}$  and the coupling speed  $n_{AN}$ .

$$T_{AN} [\text{lb-in}] = 63.000 \frac{P_{AN} [\text{HP}]}{n_{AN} [\text{rpm}]}$$

3. The **maximum torque capacity of the coupling**,  $T_{Kmax}$  shall be at least equal to the highest torque  $T_{max}$  encountered in operation while taking the temperature factor  $S_t$  into account.

$$T_{Kmax} \geq T_{max} \cdot S_t$$

4. A continuous torsional vibration analysis to verify the coupling selection should confirm that the permissible **continuous fatigue torque**  $T_{KW}$  is at least equal to the highest fatigue torque  $T_W$  under reversing stresses encountered throughout the operating speed range while taking into account the temperature and frequency.

$$T_{KW} (10 \text{ Hz}) \geq T_W \cdot S_t \cdot S_f$$

5. The **frequency factor**  $S_f$  allows for the frequency dependence of the permissible continuous fatigue torque under reversing stresses  $T_{KW}$  (10 Hz) with an operating frequency  $f_x$ .

$$S_f = \sqrt{\frac{f_x}{10}}$$



# MULTI MONT SELLA

## Service Factors

### Load classification factor $S_m$

Prime mover	Load by the driven machine		
	U (uniform load)	M (medium load)	H (heavy load)
Electric motors, turbines, hydraulic motors	1.25	1.6	2.0

### Starting factor $S_z$

Starting frequency per hour	< 30	60	120	240	> 240
$S_z$	1.0	1.1	1.2	1.3	on request

### Temperature factor $S_t$

Ambient temperature	-40 °F/+86 °F -40 °C/+30 °C	+104 °F +40 °C	+140 °F +60 °C	+176 °F +80 °C	> +176 °F > +80 °C	to +120 °C +248 °F
$S_{t(SN/UN)}$	1.0	1.1	1.4	1.8		-
$S_{t(UD)}$	1.0	1.0	1.0	1.4	1.8	2.0

### Calculation example

A coupling shall be installed between an electric motor (**P = 604 HP at n = 980 rpm**) and a belt conveyor gearbox.

Uniform load = U :  $S_m = 1.25$   
 Ambient temperature 104 °F (40 °C) :  $S_{t(UN)} = 1.1$   
 Starting frequency 30/h :  $S_z = 1.0$

$$T_{AN} = 63000 \frac{604 \text{ HP}}{980 \text{ rpm}} = 38828 \text{ lb-in}$$

$$T_{KN} \geq T_{AN} \cdot S_m \cdot S_t \cdot S_z$$

$$T_{KN} \geq 38828 \text{ lb-in} \cdot 1.25 \cdot 1.1 \cdot 1.0 = 53388.5 \text{ lb-in}$$

Selected coupling: MMS 630 .SN. W with  $T_{KN} = 66381 \text{ lb-in}$

# MULTI MONT SELLA

## Assignment of the load classification factors to the type of driven machine

U =	uniform load
M =	medium load
H =	heavy load

**i** For drives with periodic excitation of the machinery, the coupling selection shall be verified by means of a full torsional vibration analysis.

<b>DREDGES</b>		<b>GENERATORS, TRANSFORMERS</b>		Suction rolls
H Bucket conveyors		H Frequency transformers		Drying cylinders
H Traveling gears (caterpillar)		H Generators		<b>PUMPS</b>
M Traveling gears (rails)		H Welding generators		H Reciprocating pumps
M Maneuvering winches				U Centrifugal pumps (light liquids)
M Suction pumps		<b>RUBBER MACHINERY</b>		M Centrifugal pumps (viscous liquids)
H Bucket wheels		H Extruders		H Plunger pumps
H Cutter heads		H Calenders		H Pressure pumps
M Slewing gears		M Pug mills		
		M Mixers		<b>STONE AND CLAY WORKING MACHINES</b>
<b>BUILDING MACHINERY</b>		H Rolling mills		H Breakers
M Hoists				H Rotary kilns
H Concrete mixers		<b>WOOD WORKING MACHINES</b>		H Hammer mills
M Road construction machinery		H Barkers		H Ball mills
		M Planing machines		H Tube mills
<b>CHEMICAL INDUSTRY</b>		H Wood working machines		H Beater mills
M Cooling drums		H Saw frames		H Brick presses
M Mixers				
U Agitators (light liquids)		<b>CRANES</b>		<b>TEXTILE MACHINES</b>
M Agitators (viscous liquids)		H Luffing gears		M Batchers
M Drying drums		H Traveling gears		M Printing and dyeing machines
U Centrifuges (light-weight)		H Hoisting gears		M Tanning vats
M Centrifuges (heavy)		M Slewing gears		M Willows
		M Derricking jib gears		M Looms
<b>OIL INDUSTRY</b>				<b>COMPRESSORS</b>
M Pipeline pumps		<b>PLASTIC INDUSTRY MACHINER</b>		H Reciprocating compressors
H Rotary drilling equipment		H Extruders		M Centrifugal compressors
		H Calenders		
<b>CONVEYORS</b>		M Mixers		<b>METAL ROLLING MILLS</b>
M Hauling winches		M Crushers		H Plate shears
H Hoists				M Plate tilters
M Link conveyors		<b>METAL WORKING MACHINES</b>		H Ingot pushers
U Belt conveyors (bulk material)		M Sheet metal bending machines		H Block- and slab lines
H Belt conveyors (piece goods)		H Plate straightening machines		H Ingot handling machinery
M Belt bucket conveyors		H Hammers		M Wire drawing benches
M Chain conveyors		H Metal planing machines		H Descaling machines
M Circular conveyors		H Presses		H Sheet mills
M Goods lifts		H Shears		H Heavy and medium plate mills
U Flour bucket conveyors		H Forging presses		M Winding machines (strip and wire)
M Passenger lifts		H Punch presses		H Cold rolling mills
M Apron conveyors		U Counter shafts, line shafts		M Chain transfers
M Screw conveyors		M Machine tools, main drives		H Billet shears
M Ballast elevators		U Machine tools, auxiliary drives		M Cooling beds
H Inclined hoists				M Cross transfers
M Steel belt conveyors		<b>FOOD INDUSTRY MACHINERY</b>		M Roller tables (light)
M Troughed chain conveyors		U Filling machines		H Roller tables (heavy)
		M Kneading machines		M Roller straighteners
<b>BLOWERS, FANS<sup>1)</sup></b>		M Mashing apparatus, crystallizers		H Tube welding machines
U Lobe blowers P:n ≤ 0.007		U Packaging machines		M Trimming shears
M Lobe blowers P:n ≤ 0.07		M Cane crushers		H Cropping shears
H Lobe blowers P:n > 0.07		M Cane knives		H Continuous casting plants
U Blowers (axial/centrif.) P:n ≤ 0.007		H Cane mills		M Roller adjustment drives
M Blowers (axial/centrif.) P:n ≤ 0.07		M Sugar beet cutters		H Manipulators
H Blowers (axial/centrif.) P:n > 0.07		M Sugar beet washing machines		
U Cooling tower fans P:n ≤ 0.007				<b>LAUNDRIES</b>
M Cooling tower fans P:n ≤ 0.07		<b>PAPER MACHINES</b>		M Tumblers
H Cooling tower fans P:n > 0.07		H Couches		M Washing machines
U Induced draught fans P:n ≤ 0.007		H Glazing cylinders		
M Induced draught fans P:n ≤ 0.07		H Pulpers		<b>WATER TREATMENT</b>
H Induced draught fans P:n > 0.07		H Pulp grinders		M Aerators
U Turbo blowers P:n ≤ 0.007		H Calenders		U Screw pumps
M Turbo blowers P:n ≤ 0.07		H Wet presses		
H Turbo blowers P:n > 0.07		H Willows		
		H Suction presses		

**i** 1) P = power of the driven machine in kW // n = speed in min<sup>-1</sup>

# MULTI MONT SELLA

## Assignment to NEMA motor rating

### MULTI MONT SELLA coupling size, speed and torque

Torque values based on 1.6 Service Factor. For further information reference NEMA standards.

HP	900 (rpm)			1200 (rpm)			1800 (rpm)			3600 (rpm)		
	Torque [in-lbs]	Motor Shaft Range [in]	MMS Size	Torque [in-lbs]	Motor Shaft Range [in]	MMS Size	Torque [in-lbs]	Motor Shaft Range [in]	MMS Size	Torque [in-lbs]	Motor Shaft Range [in]	MMS Size
5	560	1.375"-1.625"	10	420	1.250"-1.375"	6.3	-	-	-	-	-	-
7.5	840	1.625"	10	630	1.375"-1.625"	10	420	1.250"-1.375"	6.3	210	1.125"-1.375"	4
10	1120	1.625"-1.875"	16	840	1.625"	10	560	1.375"-1.625"	10	280	1.250"-1.375"	4
15	1680	1.625"-1.875"	25	1260	1.875"	16	840	1.625"	10	420	1.375"-1.875"	6.3, 10, 16*
20	2240	2.125"	25	1680	1.625"-1.875"	25	1120	1.625"-1.875"	16	560	1.625"	6.3
25	2800	2.125"	40	2100	2.125"	25	1400	1.625"-1.875"	16	700	1.625"-1.875"	16
30	3360	2.375"	40	2520	2.125"	40	1680	1.625"-2.125"	25	840	1.625"-1.875"	16
40	4480	2.375"	63	3360	2.375"	40	2240	2.125"	25	1120	1.625"-1.875"	16
50	5600	2.625"-2.875"	63	4200	2.375"	63	2800	1.875"-2.375"	40	1400	1.875"-2.125"	25
60	6720	2.875"	100	5040	2.625"-2.875"	63	3360	1.875"-2.375"	40	1680	1.875"-2.375"	25
75	8400	3.375"	160	6300	2.875"	100	4200	1.875"-2.875"	63	2100	1.875"-2.875"	63
100	11200	3.375"	160	8400	3.375"	160	5600	2.125"-2.875"	63	2800	1.875"-2.875"	63
125	-	-	-	10500	3.375"	160	7000	2.125"-3.375"	160	3500	2.125"-2.875"	63
150	-	-	-	-	-	-	8400	2.375"	100	4200	2.125"-2.375"	63
200	-	-	-	-	-	-	11200	3.375"	160	5600	2.375"	63
250	-	-	-	-	-	-	-	-	-	7000	2.375"	100

**i** \*) Coupling selection depends on actual shaft size

# MULTI MONT SELLA

## Type MMS-T...W

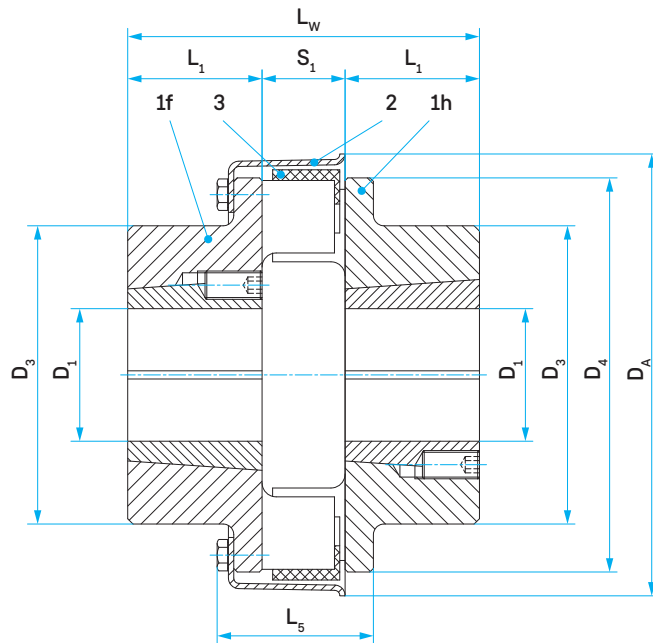

### Mounting instruction:

Thanks to the use of commercially available taper bushes with a number of different bore dimensions, the need for finishing the bore and keyway of the coupling hub is omitted for the MULTI MONT SELLA-coupling type MMS-T. Assembly and disassembly can be carried out easily without special tools! The maximum torque depends on the respective taper bush. It corresponds to a maximum of twice the nominal torque in the rubber quality 'SN'.

### Coupling details

Coupling size	$D_A$ [mm]	TB No.	$D_{1 \max}$ [mm]	$D_3$ [mm]	$D_4$ [mm]	$L_1$ [mm]	$L_5$ [mm]	$L_W$ [mm]	$S_1$ [mm]
MMS-T 25	135	1610	40	85	120	25 <sup>*)</sup>	49	72	22
MMS-T 40	155	2012	48	102	135	32 <sup>*)</sup>	52	90	26
MMS-T 63	174	2517	60	123	152	45	58	120	30
MMS-T 100	195	3030	75	145	173	76	75	187	35
MMS-T 160	221	3030	75	150	198	76	77	193	41
MMS-T 250	250	3535	90	180	223	89	88	225	47
MMS-T 400	282	4040	100	210	251	102	99	260	56
MMS-T 630	330	4040	100	215	294	102	120	268	64
MMS-T 1000	378	4545	110	240	338	115	137	285	75

**i** \*) Retracted retaining cap protrudes max. 7 mm beyond the hub for radial disassembly of the elements

### Available taper bushes

TB-No.	$D_1 =$ Metric bores with keyway acc. to DIN 6885/1																		
1610	12	14	15	16	18	19	20	22	24	25	28	30	32	35	38	40	-	-	-
2012	14	16	17	19	20	22	24	25	28	30	32	35	38	40	42	45	48	-	-
2517	16	18	19	20	22	24	25	28	30	32	35	38	40	42	45	48	50	55	60
3030	25	28	30	32	35	38	40	42	45	48	50	55	60	65	70	75	-	-	-
3535	35	38	40	42	45	48	50	55	60	65	70	75	80	85	90	-	-	-	-
4040	40	42	45	48	50	55	60	65	70	75	80	85	90	95	100	-	-	-	-
4545	55	60	65	70	75	80	85	90	95	100	105	110	-	-	-	-	-	-	-



# MULTI MONT SELLA

## Type MMS-T...W

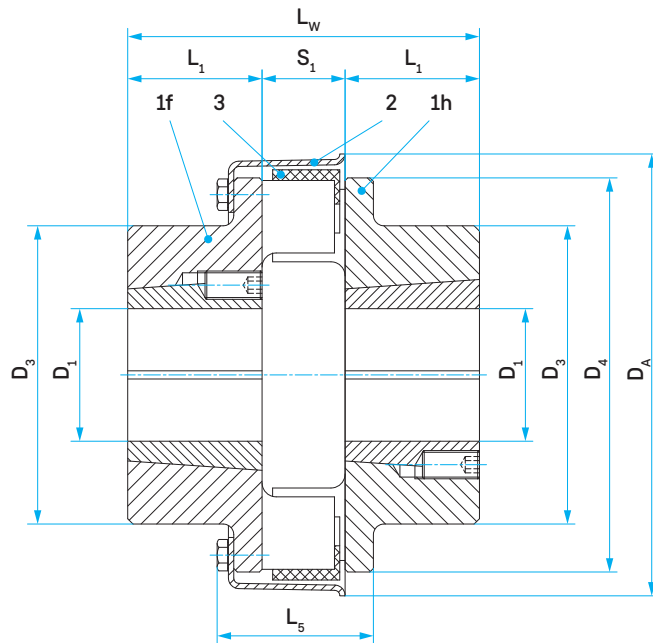

### Mounting instruction:

Thanks to the use of commercially available taper bushes with a number of different bore dimensions, the need for finishing the bore and keyway of the coupling hub is omitted for the MULTI MONT SELLA-coupling type MMS-T. Assembly and disassembly can be carried out easily without special tools! The maximum torque depends on the respective taper bush. It corresponds to a maximum of twice the nominal torque in the rubber quality 'SN'.

### Coupling details

Coupling size	DA [in]	TB No.	D1 max [in]	D3 [in]	D4 [in]	L1 [in]	L5 [in]	LW [in]	S1 [in]
MMS-T 25	5.26	1610	1.56	3.31	4.68	0.97 <sup>*)</sup>	1.93	2.80	0.85
MMS-T 40	6.04	2012	1.87	3.97	5.26	1.24 <sup>*)</sup>	2.05	3.51	1.01
MMS-T 63	6.78	2517	2.34	4.79	5.92	1.75	2.28	4.68	1.17
MMS-T 100	7.60	3030	2.92	5.65	6.74	2.96	2.95	7.29	1.36
MMS-T 160	8.61	3030	2.92	5.85	7.72	2.96	3.03	7.52	1.59
MMS-T 250	9.75	3535	3.51	7.02	8.69	3.47	3.46	8.77	1.83
MMS-T 400	10.99	4040	3.90	8.19	9.78	3.97	3.90	10.14	2.18
MMS-T 630	12.87	4040	3.90	8.38	11.46	3.97	4.72	10.45	2.49
MMS-T 1000	14.74	4545	3.90	9.36	13.18	4.48	5.39	11.11	2.92

**i** \*) Retracted retaining cap protrudes max. 0.28 in beyond the hub for radial disassembly of the elements

### Available taper bushes

TB-No.	D1 = Metric bores with keyway acc. to DIN 6885/1																		
1610	12	14	15	16	18	19	20	22	24	25	28	30	32	35	38	40	-	-	-
2012	14	16	17	19	20	22	24	25	28	30	32	35	38	40	42	45	48	-	-
2517	16	18	19	20	22	24	25	28	30	32	35	38	40	42	45	48	50	55	60
3030	25	28	30	32	35	38	40	42	45	48	50	55	60	65	70	75	-	-	-
3535	35	38	40	42	45	48	50	55	60	65	70	75	80	85	90	-	-	-	-
4040	40	42	45	48	50	55	60	65	70	75	80	85	90	95	100	-	-	-	-
4545	55	60	65	70	75	80	85	90	95	100	105	110	-	-	-	-	-	-	-

# MULTI MONT SELLA

Type MMS...W

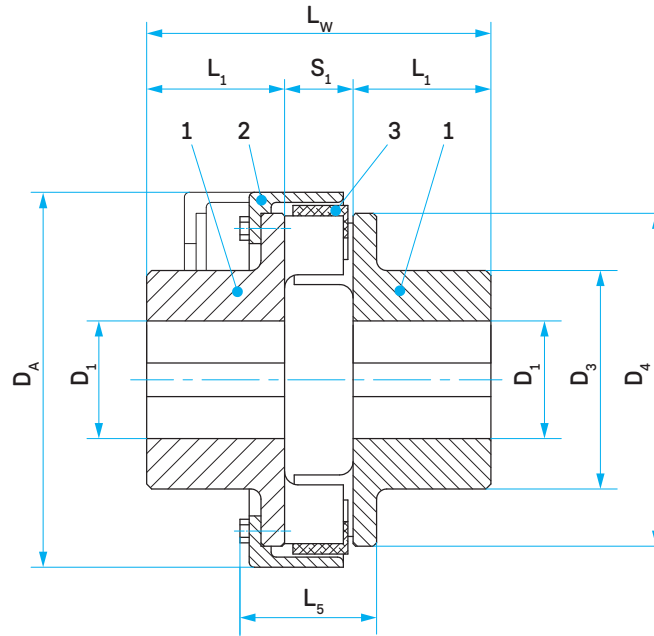

## Coupling details

Coupling size	$D_A$	$D_1$		$D_3$	$D_4$	$L_1$	$L_5$	$L_W$	$S_1$	
	[mm]	pilot bored [mm]	max. [mm]							
MMS 6.3	90	unbored/precentered	40	65	82	45	43	110	20	
MMS 10	117		45	72	96	48	44	113	17	
MMS 16	129		50	78	108	52	50	123	19	
MMS 25	135		60	88	120	57	49	136	22	
MMS 40	155		65	96	135	61	52	148	26	
MMS 63	174		75	110	152	67	58	164	30	
MMS 100	195		80	120	173	75	66	185	35	
MMS 160	221		85	130	198	82	77	205	41	
MMS 250	250		100	145	223	89	88	225	47	
MMS 400	282		105	160	251	97	99	250	56	
MMS 630	330		56	130	200	294	116	120	296	64
MMS 1000	378		68	150	225	338	140 <sup>1)</sup>	137	335	75
MMS 1600	432	88	170	255	390	160 <sup>1)</sup>	147	373	85	
MMS 2500	485	88	180	275	445	250 <sup>1)</sup>	173	510	110	
MMS 4000	553	110	200	300	500	230 <sup>1)</sup>	160	468	102	
MMS 6300	636	120	225	340	572	255 <sup>1)</sup>	176	519	113	
MMS 10000	725	130	260	390	652	285 <sup>1)</sup>	210	580	136	
MMS 16000	832	190	290	435	754	310 <sup>1)</sup>	268	635	165	
MMS 25000	938	180	330	505	852	345 <sup>1)</sup>	336	710	190	
MMS 40000	1150	220	380	580	1050	385 <sup>1)</sup>	378	792	212	
MMS 63000	1250	-	400	670	1180	440 <sup>1)</sup>	430	905	225	
MMS 100000	1400	-	320	780	1320	510 <sup>1)</sup>	520	1050	370	

<sup>1)</sup> Figure is not in accordance with actual design

# MULTI MONT SELLA

Type MMS...W

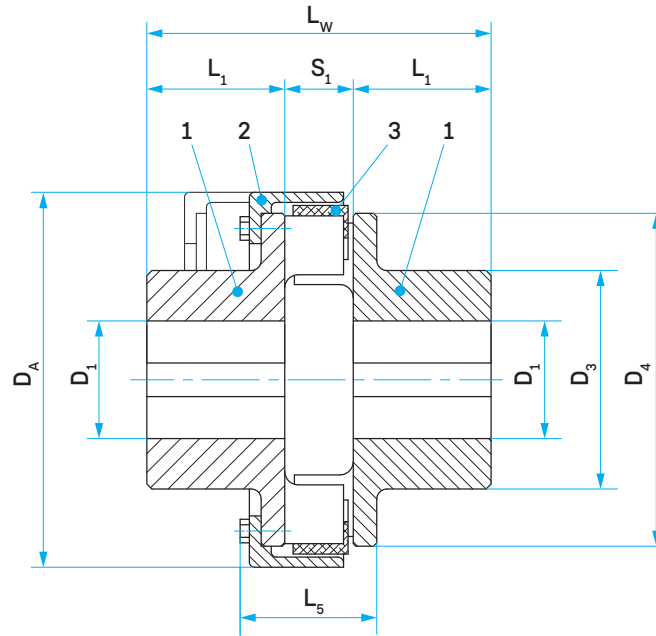

## Coupling details

Coupling size	DA	D1		D3	D4	L1	L5	Lw	S1	
	[in]	pilot bored [in]	max. [in]							
MMS 6.3	3.54	unbored/precentered	1.57	2.56	3.23	1.77	1.69	4.33	0.79	
MMS 10	4.61		1.77	2.83	3.78	1.89	1.73	4.45	0.67	
MMS 16	5.08		1.97	3.07	4.25	2.05	1.97	4.84	0.75	
MMS 25	5.31		2.36	3.46	4.72	2.24	1.93	5.35	0.87	
MMS 40	6.10		2.56	3.78	5.31	2.40	2.05	5.83	1.02	
MMS 63	6.85		2.95	4.33	5.98	2.64	2.28	6.46	1.18	
MMS 100	7.68		3.15	4.72	6.81	2.95	2.60	7.28	1.38	
MMS 160	8.70		3.35	5.12	7.80	3.23	3.03	8.07	1.61	
MMS 250	9.84		3.94	5.71	8.78	3.50	3.46	8.86	1.85	
MMS 400	11.10		4.13	6.30	9.88	3.82	3.90	9.84	2.20	
MMS 630	12.99		2.20	5.12	7.87	11.57	4.57	4.72	11.65	2.52
MMS 1000	14.88		2.68	5.91	8.86	13.31	5.51 <sup>1)</sup>	5.39	13.19	2.95
MMS 1600	17.01	3.46	6.69	10.04	15.35	6.30 <sup>1)</sup>	5.79	14.69	3.35	
MMS 2500	19.09	3.46	7.09	10.83	17.52	9.84 <sup>1)</sup>	6.81	20.08	4.33	
MMS 4000	21.77	4.33	7.87	11.81	19.69	9.06 <sup>1)</sup>	6.30	18.43	4.02	
MMS 6300	25.04	4.72	8.86	13.39	22.52	10.04 <sup>1)</sup>	6.93	20.43	4.45	
MMS 10000	28.54	5.12	10.24	15.35	25.67	11.22 <sup>1)</sup>	8.27	22.83	5.35	
MMS 16000	32.76	7.48	11.24	17.13	29.685	12.20 <sup>1)</sup>	10.55	25.00	6.50	
MMS 25000	36.93	7.09	12.99	19.88	33.543	13.58 <sup>1)</sup>	13.23	27.95	7.48	
MMS 40000	45.28	8.66	14.96	22.83	41.339	15.16 <sup>1)</sup>	14.88	31.18	8.35	
MMS 63000	49.21	-	15.75	26.38	46.457	17.32 <sup>1)</sup>	16.93	35.63	8.86	
MMS 100000	55.12	-	12.60	30.71	51.969	20.08 <sup>1)</sup>	20.47	41.34	14.57	

<sup>1)</sup> Figure is not in accordance with actual design

# MULTI MONT SELLA

Type MMS...F1

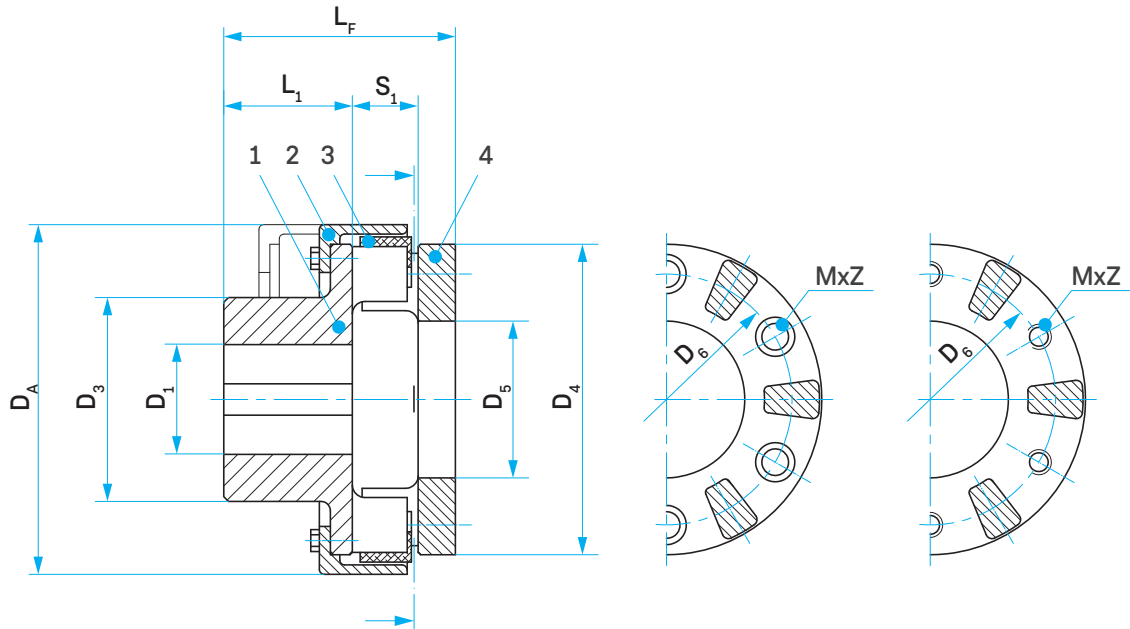

## Coupling details

Coupling size	$D_A$	pilot bored	$D_1$	$D_3$	$D_4$	$D_5$	$D_6$	M	Z	$L_1$	$L_F$	$S_1$
	[mm]		max. [mm]	[mm]	[mm]	[mm]	[mm]					
MMS 6.3	90	unbored/precentered	40	65	82	40	60	M6	4	45	75	20
MMS 10	117		45	72	96	50	80	M8	6	48	78	17
MMS 16	129		50	78	108	58	92	M8	6	52	84	19
MMS 25	135		60	88	120	65	101	M10	6	57	94	22
MMS 40	155		65	96	135	70	114	M10	6	61	102	26
MMS 63	174		75	110	152	78	126	M12	6	67	115	30
MMS 100	195		80	120	173	90	148	M12	12	75	131	35
MMS 160	221		85	130	198	100	162	M16	6	82	147	41
MMS 250	250		100	145	223	115	180	M16	6	89	163	47
MMS 400	282		105	160	251	125	206	M20	6	97	183	56
MMS 630	330	56	130	200	294	150	238	M20	12	116	210	64
MMS 1000	378	68	150	225	338	175	278	M20	12	140 <sup>1)</sup>	235	75
MMS 1600	432	88	170	255	390	200	322	M20	18	160 <sup>1)</sup>	260	85
MMS 2500	485	88	180	275	445	240	360	M24	18	250 <sup>1)</sup>	360	110
MMS 4000	553	110	200	300	500	250	420	M24	18	230 <sup>1)</sup>	316	102
MMS 6300	636	120	225	340	572	275	494	M24	18	255 <sup>1)</sup>	350	113
MMS 10000	725	130	260	390	652	305	576	M30	18	285 <sup>1)</sup>	390	136
MMS 16000	832	190	290	435	754	350	620	M30 <sup>2)</sup>	18	310 <sup>1)</sup>	440	165
MMS 25000	938	180	330	505	852	380	740	M30 <sup>2)</sup>	18	345 <sup>1)</sup>	508	190
MMS 40000	1150	220	380	580	1050	460	950	M30 <sup>2)</sup>	36	385 <sup>1)</sup>	572	212
MMS 63000	1250	-	400	670	1180	580	1050	M30 <sup>2)</sup>	36	440 <sup>1)</sup>	650	225
MMS 100000	1400	-	520	780	1320	600	1200	M30 <sup>2)</sup>	36	510 <sup>1)</sup>	760	370



1) Figure is not in accordance with actual design

2) In order for the torque to be transmitted reliably, the bolted connection of the flanges must be supported by a suitable positive connection such as e.g. pins



# MULTI MONT SELLA

Type MMS...F1

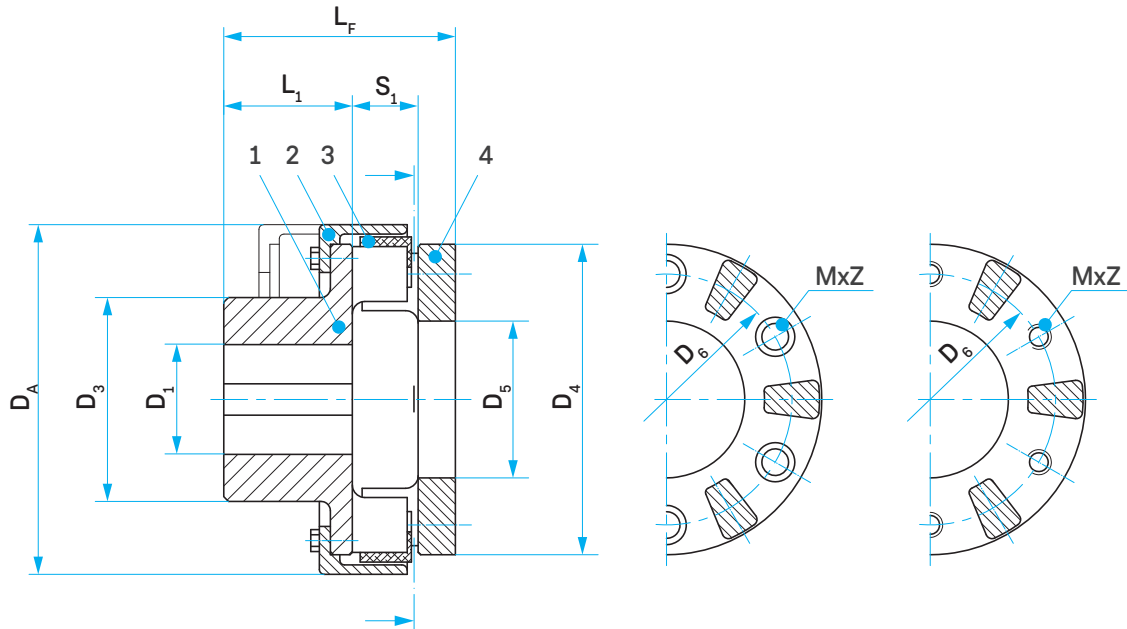

## Coupling details

Coupling size	D <sub>A</sub>	D <sub>1</sub> pilot bored [in]	D <sub>3</sub> max. [in]	D <sub>4</sub> [in]	D <sub>5</sub> H <sub>9</sub> [in]	D <sub>6</sub> [in]	M	Z	L <sub>1</sub> [in]	L <sub>F</sub> [in]	S <sub>1</sub> [in]	
	[in]											
MMS 6.3	3.54	unbored/precentered	1.57	2.56	3.23	1.575	2.36	M6	4	1.77	2.95	0.79
MMS 10	4.61		1.77	2.83	3.78	1.969	3.15	M8	6	1.89	3.07	0.67
MMS 16	5.08		1.97	3.07	4.25	2.283	3.62	M8	6	2.05	3.31	0.75
MMS 25	5.31		2.36	3.46	4.72	2.559	3.98	M10	6	2.24	3.70	0.87
MMS 40	6.10		2.56	3.78	5.31	2.756	4.49	M10	6	2.40	4.02	1.02
MMS 63	6.85		2.95	4.33	5.98	3.071	4.96	M12	6	2.64	4.53	1.18
MMS 100	7.68		3.15	4.72	6.81	3.543	5.83	M12	12	2.95	5.16	1.38
MMS 160	8.70		3.35	5.12	7.80	3.937	6.38	M16	6	3.23	5.79	1.61
MMS 250	9.84		3.94	5.71	8.78	4.528	7.09	M16	6	3.50	6.42	1.85
MMS 400	11.10		4.13	6.30	9.88	4.921	8.11	M20	6	3.82	7.20	2.20
MMS 630	12.99	2.20	5.12	7.87	11.57	5.906	9.37	M20	12	4.57	8.27	2.52
MMS 1000	14.88	2.68	5.91	8.86	13.31	6.890	10.94	M20	12	5.51 <sup>1)</sup>	9.25	2.95
MMS 1600	17.01	3.46	6.69	10.04	15.35	7.874	12.68	M20	18	6.30 <sup>1)</sup>	10.24	3.35
MMS 2500	19.09	3.46	7.09	10.83	17.52	9.449	14.17	M24	18	9.84 <sup>1)</sup>	14.17	4.33
MMS 4000	21.77	4.33	7.87	11.81	19.69	9.843	16.54	M24	18	9.84 <sup>1)</sup>	12.44	4.02
MMS 6300	25.04	4.72	8.86	13.39	22.52	10.827	19.45	M24	18	10.83 <sup>1)</sup>	13.78	4.45
MMS 10000	28.54	5.12	10.24	15.35	25.67	12.008	22.68	M30	18	12.01 <sup>1)</sup>	15.35	5.35
MMS 16000	32.76	7.48	11.42	17.13	29.685	13.780	24.41	M30 <sup>2)</sup>	18	13.780 <sup>1)</sup>	17.32	6.50
MMS 25000	36.93	7.09	12.99	19.88	33.543	14.961	29.13	M30 <sup>2)</sup>	18	14.961 <sup>1)</sup>	20.00	7.48
MMS 40000	45.28	8.66	14.96	22.83	41.339	18.110	37.40	M30 <sup>2)</sup>	36	18.110 <sup>1)</sup>	22.52	8.35
MMS 63000	49.21	-	15.75	26.38	46.457	22.835	41.34	M30 <sup>2)</sup>	36	22.835 <sup>1)</sup>	25.59	8.86
MMS 100000	55.12	-	20.47	30.71	51.969	23.622	47.24	M30 <sup>2)</sup>	36	23.622 <sup>1)</sup>	29.92	14.57

- 1) Figure is not in accordance with actual design
- 2) In order for the torque to be transmitted reliably, the bolted connection of the flanges must be supported by a suitable positive connection such as e.g. pins

# MULTI MONT SELLA

Type MMS...T

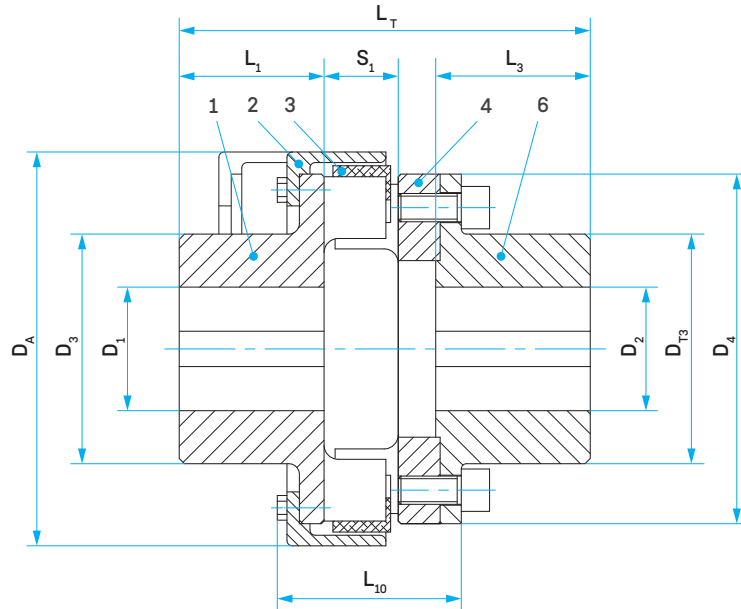

## Coupling details

Coupling size	D <sub>A</sub> [mm]	D <sub>1</sub> pilot bored [mm]	D <sub>2</sub>	D <sub>3</sub>	D <sub>T3</sub>	D <sub>4</sub>	L <sub>1</sub>	L <sub>3</sub>	L <sub>10</sub>	L <sub>T</sub>	S <sub>1</sub>	
			max. [mm]	max. [mm]	[mm]	[mm]	[mm]	[mm]	[mm]	[mm]	[mm]	[mm]
MMS 10	117	unbored/precentered	45	40	72	64	96	48	52	57	128	17
MMS 16	129		50	45	78	72	108	52	57	63	139	19
MMS 25	135		60	50	88	78	120	57	62	68	154	22
MMS 40	155		65	60	96	96	135	61	68	76	168	26
MMS 63	174		75	65	110	104	152	67	75	85	188	30
MMS 100	195		80	75	120	118	173	75	82	97	211	35
MMS 160	221		85	80	130	130	198	82	88	111	232	41
MMS 250	250		100	90	145	145	223	89	98	124	258	47
MMS 400	282		105	100	160	160	251	97	105	141	285	56
MMS 630	330		56	130	130	200	195	294	116	134	145	341
MMS 1000	378	68	150	140	225	225	338	140 <sup>1)</sup>	154	163	386	75
MMS 1600	432	88	170	160	255	255	390	160 <sup>1)</sup>	170	177	426	85
MMS 2500	485	88	180	180	275	275	445	250 <sup>1)</sup>	250	232	606	110
MMS 4000	553	110	200	180	300	300	500	230 <sup>1)</sup>	230 <sup>1)</sup>	192	542	102
MMS 6300	636	120	225	205	340	340	572	255 <sup>1)</sup>	255 <sup>1)</sup>	215	601	113
MMS 10000	725	130	260	235	390	390	652	285 <sup>1)</sup>	285 <sup>1)</sup>	242	670	136
MMS 16000	832	190	290	265	435	450	754	310 <sup>1)</sup>	310 <sup>1)</sup>	282	740	165
MMS 25000	938	180	330	300	505	500	852	345 <sup>1)</sup>	345 <sup>1)</sup>	336	845	190
MMS 40000	1150	220	380	350	580	580	1050	385 <sup>1)</sup>	385 <sup>1)</sup>	378	942	212
MMS 63000	1250	-	400	400	670	670	1180	440 <sup>1)</sup>	440 <sup>1)</sup>	430	1065	225
MMS 100000	1400	-	520	475	780	780	1320	510 <sup>1)</sup>	510 <sup>1)</sup>	520	1260	370

<sup>1)</sup> Figure is not in accordance with actual design

# MULTI MONT SELLA

Type MMS...T

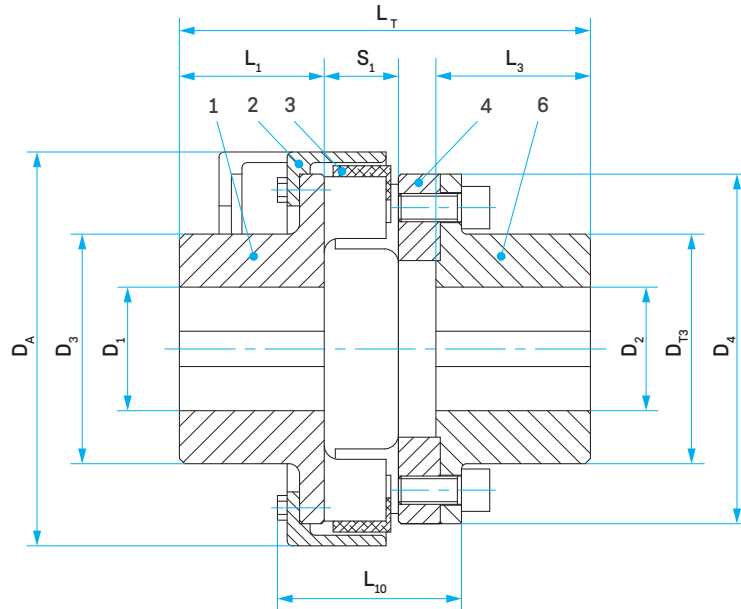

## Coupling details

Coupling size	D <sub>A</sub> [in]	D <sub>1</sub> pilot bored [in]	D <sub>2</sub>	D <sub>3</sub>	D <sub>T3</sub>	D <sub>4</sub>	L <sub>1</sub>	L <sub>3</sub>	L <sub>10</sub>	L <sub>T</sub>	S <sub>1</sub>	
			max. [in]	max. [in]	[in]	[in]	[in]	[in]	[in]	[in]	[in]	[in]
MMS 10	4.61	unbored/precentered	1.77	1.57	2.83	2.52	3.78	1.89	2.05	2.24	5.04	0.67
MMS 16	5.08		1.97	1.77	3.07	2.83	4.25	2.05	2.24	2.48	5.47	0.75
MMS 25	5.31		2.36	1.97	3.46	3.07	4.72	2.24	2.44	2.68	6.06	0.87
MMS 40	6.10		2.56	2.36	3.78	3.78	5.31	2.40	2.68	2.99	6.61	1.02
MMS 63	6.85		2.95	2.56	4.33	4.09	5.98	2.64	2.95	3.35	7.40	1.18
MMS 100	7.68		3.15	2.95	4.72	4.65	6.81	2.95	3.23	3.82	8.31	1.38
MMS 160	8.70		3.35	3.15	5.12	5.12	7.80	3.23	3.46	4.37	9.13	1.61
MMS 250	9.84		3.94	3.54	5.71	5.71	8.78	3.50	3.86	4.88	10.16	1.85
MMS 400	11.10		4.13	3.94	6.30	6.30	9.88	3.82	4.13	5.55	11.22	2.20
MMS 630	12.99		2.20	5.12	5.12	7.87	7.68	11.57	4.57	5.28	5.71	13.43
MMS 1000	14.88	2.68	5.91	5.51	8.86	8.86	13.31	5.51 <sup>1)</sup>	6.06	6.42	15.20	2.95
MMS 1600	17.01	3.46	6.69	6.30	10.04	10.04	15.35	6.30 <sup>1)</sup>	6.69	6.97	16.77	3.35
MMS 2500	19.09	3.46	7.09	7.09	10.83	10.83	17.52	9.84 <sup>1)</sup>	9.84	9.13	23.86	4.33
MMS 4000	21.77	4.33	7.87	7.09	11.81	11.81	19.69	9.06 <sup>1)</sup>	9.06 <sup>1)</sup>	7.56	21.34	4.02
MMS 6300	25.04	4.72	8.86	8.07	13.39	13.39	22.52	10.04 <sup>1)</sup>	10.04 <sup>1)</sup>	8.46	23.66	4.45
MMS 10000	28.54	5.12	10.24	9.25	15.35	15.35	25.67	11.22 <sup>1)</sup>	11.22 <sup>1)</sup>	9.53	26.38	5.35
MMS 16000	32.76	7.48	11.42	10.43	17.13	17.72	29.685	12.20 <sup>1)</sup>	12.20 <sup>1)</sup>	11.10	29.13	6.50
MMS 25000	36.93	7.09	12.99	11.81	19.88	19.69	33.543	13.58 <sup>1)</sup>	13.58 <sup>1)</sup>	13.23	33.27	7.48
MMS 40000	45.28	8.66	14.96	13.78	22.83	22.83	41.339	15.16 <sup>1)</sup>	15.16 <sup>1)</sup>	14.88	37.09	8.35
MMS 63000	49.21	-	15.75	15.75	26.38	26.38	46.457	17.32 <sup>1)</sup>	17.32 <sup>1)</sup>	16.93	41.93	8.86
MMS 100000	55.12	-	20.47	18.70	30.71	30.71	51.969	20.08 <sup>1)</sup>	20.08 <sup>1)</sup>	20.47	49.61	14.57

<sup>1)</sup> Figure is not in accordance with actual design

# MULTI MONT SELLA

Type MMS...WBS

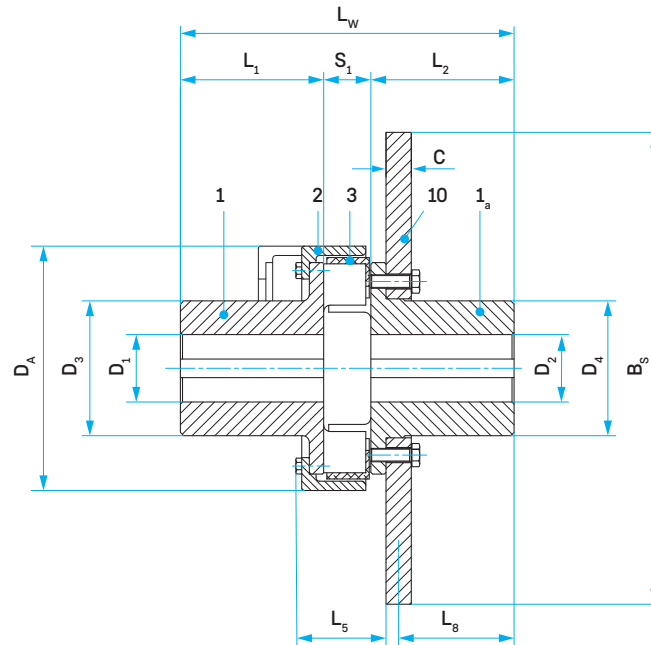

## Coupling details

Coupling size	$B_S$	C	$D_A$	$D_1/D_2$		$D_3$	$D_4$	$L_1$		$L_2$	$L_5$	$L_8$	$L_w$		$S_1$	
				pilot bored	max.			norm.	long				norm.	long.		
	[mm]	[mm]	[mm]	[mm]	[mm]	[mm]	[mm]	[mm]	[mm]	[mm]	[mm]	[mm]	[mm]	[mm]	[mm]	
MMS 40 WBS 315	315	30	155	unbored/precentered	65	96	94	61	110	110	50	85.5	197	246	26	
MMS 63 WBS 355	355	30	174		75	110	110	67	110	110	57	84.5	207	250	30	
MMS 63 WBS 400	400	30	174		75	110	110	67	110	110	57	84.5	207	250	30	
MMS 100 WBS 450	450	30	195		80	120	118	75	140	140	69	110.5	250	315	35	
MMS 100 WBS 500	500	30	195		80	120	118	75	140	140	69	110.5	250	315	35	
MMS 160 WBS 450	450	30	221		85	130	130	82	140	140	77	110.5	263	321	41	
MMS 160 WBS 500	500	30	221		85	130	130	82	140	140	77	110.5	263	321	41	
MMS 160 WBS 560	560	30	221		85	130	130	82	140	140	77	110.5	263	321	41	
MMS 250 WBS 500	500	30	252		100	145	145	89	170	170	93	138.5	306	387	47	
MMS 250 WBS 560	560	30	252		100	145	145	89	170	170	93	138.5	306	387	47	
MMS 250 WBS 630	630	30	252		100	145	145	89	170	170	93	138.5	306	387	47	
MMS 400 WBS 560	560	30	290		105	160	160	97	170	170	107	136.5	323	396	56	
MMS 400 WBS 630	630	30	290		105	160	160	97	170	170	107	136.5	323	396	56	
MMS 400 WBS 710	710	30	290		105	160	160	97	170	170	107	136.0	323	396	56	
MMS 630 WBS 630	630	30	330		56	130	200	192	116	210	210	120	175.5	390	484	64
MMS 630 WBS 710	710	30	330		56	130	200	192	116	210	210	120	175.0	390	484	64
MMS 630 WBS 800	800	30	330		56	130	200	192	116	210	210	120	175.0	390	484	64
MMS 1000 WBS 710	710	30	378		68	150	225	225	140 <sup>1)</sup>	210 <sup>1)</sup>	210 <sup>1)</sup>	137	162.0	405	475	75
MMS 1000 WBS 800	800	30	378	68	150	225	225	140 <sup>1)</sup>	210 <sup>1)</sup>	210 <sup>1)</sup>	137	162.0	405	475	75	
MMS 1000 WBS 1000	1000	40	378	68	150	225	225	140 <sup>1)</sup>	210 <sup>1)</sup>	210 <sup>1)</sup>	137	157.0	405	475	75	
MMS 1600 WBS 1000	1000	40	432	88	170	255	252	160 <sup>1)</sup>	210 <sup>1)</sup>	210 <sup>1)</sup>	148	150.0	423	473	85	
MMS 2500 WBS 1000	1000	40	485	88	180	275	270	250 <sup>1)</sup>	-	250 <sup>1)</sup>	173	155.0	510	-	110	

<sup>1)</sup> Figure is not in accordance with actual design

# MULTI MONT SELLA

Type MMS...WBS

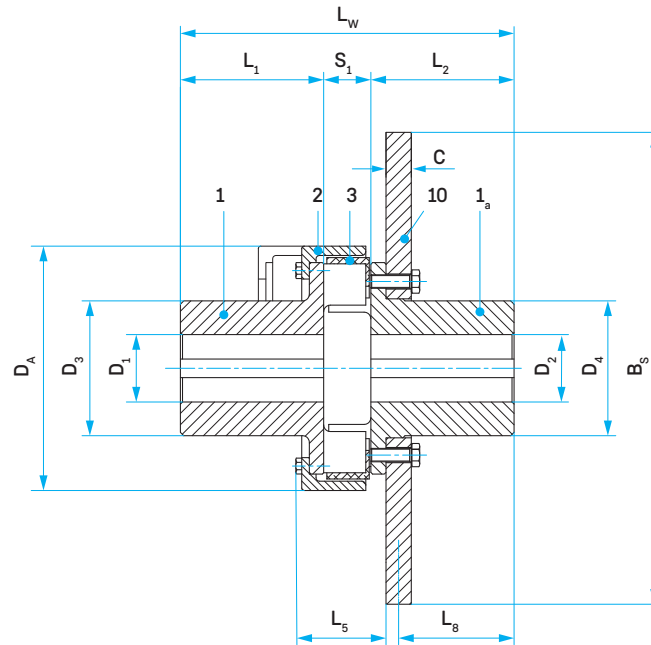

## Coupling details

Coupling size	B <sub>S</sub>	C	D <sub>A</sub>	D <sub>1</sub> /D <sub>2</sub>		D <sub>3</sub>	D <sub>4</sub>	L <sub>1</sub>		L <sub>2</sub>	L <sub>5</sub>	L <sub>8</sub>	L <sub>w</sub>		S <sub>1</sub>
				pilot bored	max.			norm.	long				norm.	long.	
	[in]	[in]	[in]	[in]	[in]	[in]	[in]	[in]	[in]	[in]	[in]	[in]	[in]	[in]	[in]
MMS 40 WBS 315	12.40	1.18	6.10		2.56	3.78	3.70	2.40	4.33	4.33	1.97	3.37	7.76	9.69	1.02
MMS 63 WBS 355	13.98	1.18	6.85		2.95	4.33	4.33	2.64	4.33	4.33	2.24	3.33	8.15	9.84	1.18
MMS 63 WBS 400	15.75	1.18	6.85		2.95	4.33	4.33	2.64	4.33	4.33	2.24	3.33	8.15	9.84	1.18
MMS 100 WBS 450	17.72	1.18	7.68		3.15	4.72	4.65	2.95	5.51	5.51	2.72	4.35	9.84	12.40	1.38
MMS 100 WBS 500	19.69	1.18	7.68		3.15	4.72	4.65	2.95	5.51	5.51	2.72	4.35	9.84	12.40	1.38
MMS 160 WBS 450	17.72	1.18	8.70		3.35	5.12	5.12	3.23	5.51	5.51	3.03	4.35	10.35	12.64	1.61
MMS 160 WBS 500	19.69	1.18	8.70		3.35	5.12	5.12	3.23	5.51	5.51	3.03	4.35	10.35	12.64	1.61
MMS 160 WBS 560	22.05	1.18	8.70		3.35	5.12	5.12	3.23	5.51	5.51	3.03	4.35	10.35	12.64	1.61
MMS 250 WBS 500	19.69	1.18	9.92		3.94	5.71	5.71	3.50	6.69	6.69	3.66	5.45	12.05	15.24	1.85
MMS 250 WBS 560	22.05	1.18	9.92		3.94	5.71	5.71	3.50	6.69	6.69	3.66	5.45	12.05	15.24	1.85
MMS 250 WBS 630	24.80	1.18	9.92		3.94	5.71	5.71	3.50	6.69	6.69	3.66	5.45	12.05	15.24	1.85
MMS 400 WBS 560	22.05	1.18	11.42		4.13	6.30	6.30	3.82	6.69	6.69	4.21	5.37	12.72	15.59	2.20
MMS 400 WBS 630	24.80	1.18	11.42		4.13	6.30	6.30	3.82	6.69	6.69	4.21	5.37	12.72	15.59	2.20
MMS 400 WBS 710	27.95	1.18	11.42		4.13	6.30	6.30	3.82	6.69	6.69	4.21	5.35	12.72	15.59	2.20
MMS 630 WBS 630	24.80	1.18	12.99	2.20	5.12	7.87	7.56	4.57	8.27	8.27	4.72	6.91	15.35	19.06	2.52
MMS 630 WBS 710	27.95	1.18	12.99	2.20	5.12	7.87	7.56	4.57	8.27	8.27	4.72	6.89	15.35	19.06	2.52
MMS 630 WBS 800	31.50	1.18	12.99	2.20	5.12	7.87	7.56	4.57	8.27	8.27	4.72	6.89	15.35	19.06	2.52
MMS 1000 WBS 710	27.95	1.18	14.88	2.68	5.91	8.86	8.86	5.51 <sup>1)</sup>	8.27 <sup>1)</sup>	8.27 <sup>1)</sup>	5.39	6.38	15.94	18.70	2.95
MMS 1000 WBS 800	31.50	1.18	14.88	2.68	5.91	8.86	8.86	5.51 <sup>1)</sup>	8.27 <sup>1)</sup>	8.27 <sup>1)</sup>	5.39	6.38	15.94	18.70	2.95
MMS 1000 WBS 1000	39.37	1.57	14.88	2.68	5.91	8.86	8.86	5.51 <sup>1)</sup>	8.27 <sup>1)</sup>	8.27 <sup>1)</sup>	5.39	6.18	15.94	18.70	2.95
MMS 1600 WBS 1000	39.37	1.57	17.01	3.46	6.69	10.04	9.92	6.30 <sup>1)</sup>	8.27 <sup>1)</sup>	8.27 <sup>1)</sup>	5.83	5.91	16.65	18.62	3.35
MMS 2500 WBS 1000	39.37	1.18	19.09	3.46	7.09	10.83	10.63	7.87 <sup>1)</sup>	-	9.84 <sup>1)</sup>	6.81	6.10	18.11	-	4.33

1) Figure is not in accordance with actual design

# MULTI MONT SELLA

Type MMS...TBS

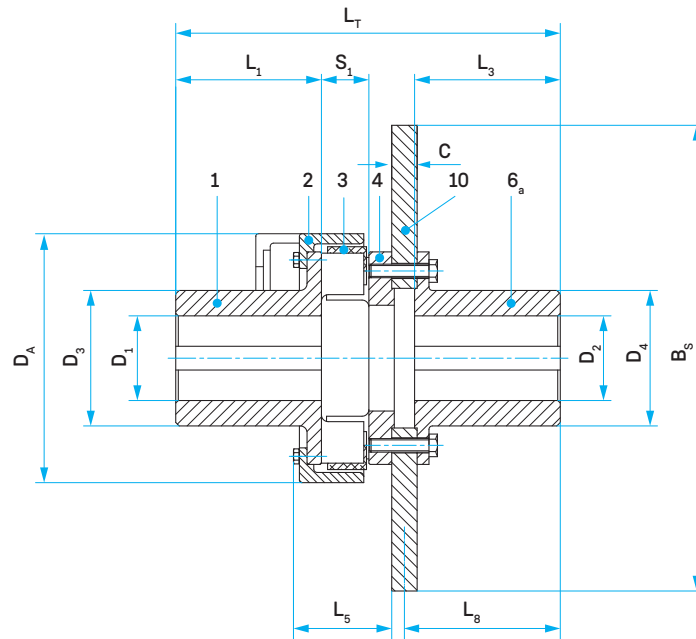

## Coupling details

Coupling size	$B_S$	C	$D_A$	$D_1/D_2$		$D_3$	$D_4$	$L_1$		$L_3$	$L_5$	$L_8$	$L_T$		$S_1$
				pilot bored	max.			norm.	long.				norm.	long.	
	[mm]	[mm]	[mm]	[mm]	[mm]	[mm]	[mm]	[mm]	[mm]	[mm]	[mm]	[mm]	[mm]	[mm]	[mm]
MMS 40 TBS 315	315	30	155		65	94	96	61	110	110	56	123.5	239	288	26
MMS 63 TBS 355	355	30	174		75	110	110	67	110	110	67	123.5	252	295	30
MMS 63 TBS 400	400	30	174		75	110	110	67	110	110	67	123.5	252	295	30
MMS 100 TBS 400	400	30	195		80	120	120	75	140	140	78	153.5	298	363	35
MMS 100 TBS 450	450	30	195		80	120	120	75	140	140	78	153.5	298	363	35
MMS 100 TBS 500	500	30	195		80	120	120	75	140	140	78	153.5	298	363	35
MMS 160 TBS 450	450	30	221		85	130	130	82	140	140	85	153.5	314	372	41
MMS 160 TBS 500	500	30	221		85	130	130	82	140	140	85	153.5	314	372	41
MMS 160 TBS 560	560	30	221		85	130	130	82	140	140	85	153.5	314	372	41
MMS 250 TBS 500	500	30	252		100	145	145	89	170	170	102	182.5	359	440	47
MMS 250 TBS 560	560	30	252		100	145	145	89	170	170	102	182.5	359	440	47
MMS 250 TBS 630	630	30	252		100	145	145	89	170	170	102	182.5	359	440	47
MMS 400 TBS 630	630	30	290		105	160	160	97	170	170	118	182.5	378	451	56
MMS 400 TBS 710	710	30	290		105	160	160	97	170	170	118	183.0	379	452	56
MMS 630 TBS 630	630	30	330	56	130	200	195	116	210	210	127	223.0	446	539	64
MMS 630 TBS 710	710	30	330	56	130	200	195	116	210	210	127	223.0	446	539	64
MMS 630 TBS 800	800	30	330	56	130	200	195	116	210	210	127	223.0	446	539	64
MMS 1000 TBS 710	710	30	378	68	150	225	225	140 <sup>1)</sup>	210 <sup>1)</sup>	210	140	223.0	471	541	75
MMS 1000 TBS 800	800	30	378	68	150	225	225	140 <sup>1)</sup>	210 <sup>1)</sup>	210	140	223.0	471	541	75
MMS 1000 TBS 1000	1000	40	378	68	150	225	225	140 <sup>1)</sup>	210 <sup>1)</sup>	210	140	228.0	481	551	75
MMS 1600 TBS 800	800	30	432	88	170	255	255	160 <sup>1)</sup>	210 <sup>1)</sup>	210	153	223.0	495	545	85
MMS 1600 TBS 1000	1000	40	432	88	170	255	255	160 <sup>1)</sup>	210 <sup>1)</sup>	210	153	228.0	505	555	85
MMS 2500 TBS 1000	1000	40	485	88	180	275	300	250 <sup>1)</sup>	-	250	185	247.0	624	624	110

1) Figure is not in accordance with actual design



# MULTI MONT SELLA

Type MMS...TBS

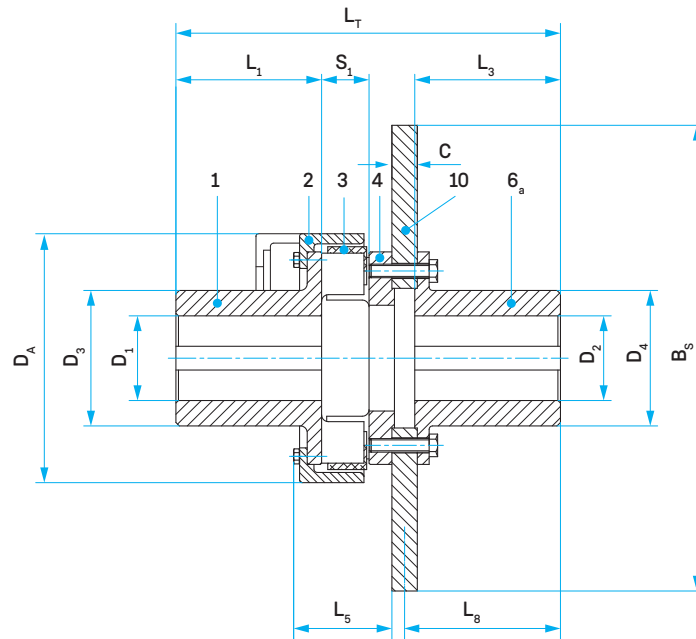

## Coupling details

Coupling size	$B_5$ [in]	C [in]	$D_A$ [in]	$D_1/D_2$		$D_3$ [in]	$D_4$ [in]	$L_1$		$L_3$ [in]	$L_5$ [in]	$L_8$ [in]	$L_T$		$S_1$ [in]
				pilot bored [in]	max. [in]			norm. [in]	long. [in]				norm. [in]	long. [in]	
MMS 40 TBS 315	12.40	1.18	6.10		2.56	3.78	3.78	2.40	4.33	4.33	2.20	4.86	9.41	11.34	1.02
MMS 63 TBS 355	13.98	1.18	6.85		2.95	4.33	4.33	2.64	4.33	4.33	2.64	4.86	9.92	11.61	1.18
MMS 63 TBS 400	15.75	1.18	6.85		2.95	4.33	4.33	2.64	4.33	4.33	2.64	4.86	9.92	11.61	1.18
MMS 100 TBS 400	15.75	1.18	7.68		3.15	4.72	4.72	2.95	5.51	5.51	3.07	6.04	11.73	14.29	1.38
MMS 100 TBS 450	17.72	1.18	7.68		3.15	4.72	4.72	2.95	5.51	5.51	3.07	6.04	11.73	14.29	1.38
MMS 100 TBS 500	19.69	1.18	7.68		3.15	4.72	4.72	2.95	5.51	5.51	3.07	6.04	11.73	14.29	1.38
MMS 160 TBS 450	17.72	1.18	8.70		3.35	5.12	5.12	3.23	5.51	5.51	3.35	6.04	12.36	14.65	1.61
MMS 160 TBS 500	19.69	1.18	8.70		3.35	5.12	5.12	3.23	5.51	5.51	3.35	6.04	12.36	14.65	1.61
MMS 160 TBS 560	22.05	1.18	8.70		3.35	5.12	5.12	3.23	5.51	5.51	3.35	6.04	12.36	14.65	1.61
MMS 250 TBS 500	19.69	1.18	9.92		3.94	5.71	5.71	3.50	6.69	6.69	4.02	7.19	14.13	17.32	1.85
MMS 250 TBS 560	22.05	1.18	9.92		3.94	5.71	5.71	3.50	6.69	6.69	4.02	7.19	14.13	17.32	1.85
MMS 250 TBS 630	24.80	1.18	9.92		3.94	5.71	5.71	3.50	6.69	6.69	4.02	7.19	14.13	17.32	1.85
MMS 400 TBS 630	24.80	1.18	11.42		4.13	6.30	6.30	3.82	6.69	6.69	4.65	7.19	14.88	17.76	2.20
MMS 400 TBS 710	27.95	1.18	11.42		4.13	6.30	6.30	3.82	6.69	6.69	4.65	7.20	14.92	21.34	2.20
MMS 630 TBS 630	24.80	1.18	12.99	2.20	5.12	7.87	7.68	4.57	8.27	8.27	5.00	8.78	17.56	21.22	2.52
MMS 630 TBS 710	27.95	1.18	12.99	2.20	5.12	7.87	7.68	4.57	8.27	8.27	5.00	8.78	17.56	21.22	2.52
MMS 630 TBS 800	31.50	1.18	12.99	2.20	5.12	7.87	7.68	4.57	8.27	8.27	5.00	8.78	17.56	21.22	2.52
MMS 1000 TBS 710	27.95	1.18	14.88	2.68	5.91	8.86	8.86	5.51 <sup>1)</sup>	8.27 <sup>1)</sup>	8.27	5.51	8.78	18.54	21.30	2.95
MMS 1000 TBS 800	31.50	1.18	14.88	2.68	5.91	8.86	8.86	5.51 <sup>1)</sup>	8.27 <sup>1)</sup>	8.27	5.51	8.78	18.54	21.30	2.95
MMS 1000 TBS 1000	39.37	1.57	14.88	2.68	5.91	8.86	8.86	5.51 <sup>1)</sup>	8.27 <sup>1)</sup>	8.27	5.51	8.98	18.94	21.69	2.95
MMS 1600 TBS 800	31.50	1.18	17.01	3.46	6.69	10.04	10.04	6.30 <sup>1)</sup>	8.27 <sup>1)</sup>	8.27	6.02	8.78	19.49	21.46	3.35
MMS 1600 TBS 1000	39.37	1.57	17.01	3.46	6.69	10.04	10.04	6.30 <sup>1)</sup>	8.27 <sup>1)</sup>	8.27	6.02	8.98	19.88	21.85	3.35
MMS 2500 TBS 1000	39.37	1.18	19.09	3.46	7.09	10.83	11.81	7.87 <sup>1)</sup>	-	9.84 <sup>1)</sup>	7.28	10.31	22.60	24.57	4.33

<sup>1)</sup> Figure is not in accordance with actual design

# MULTI MONT SELLA

Type MMS...WBT

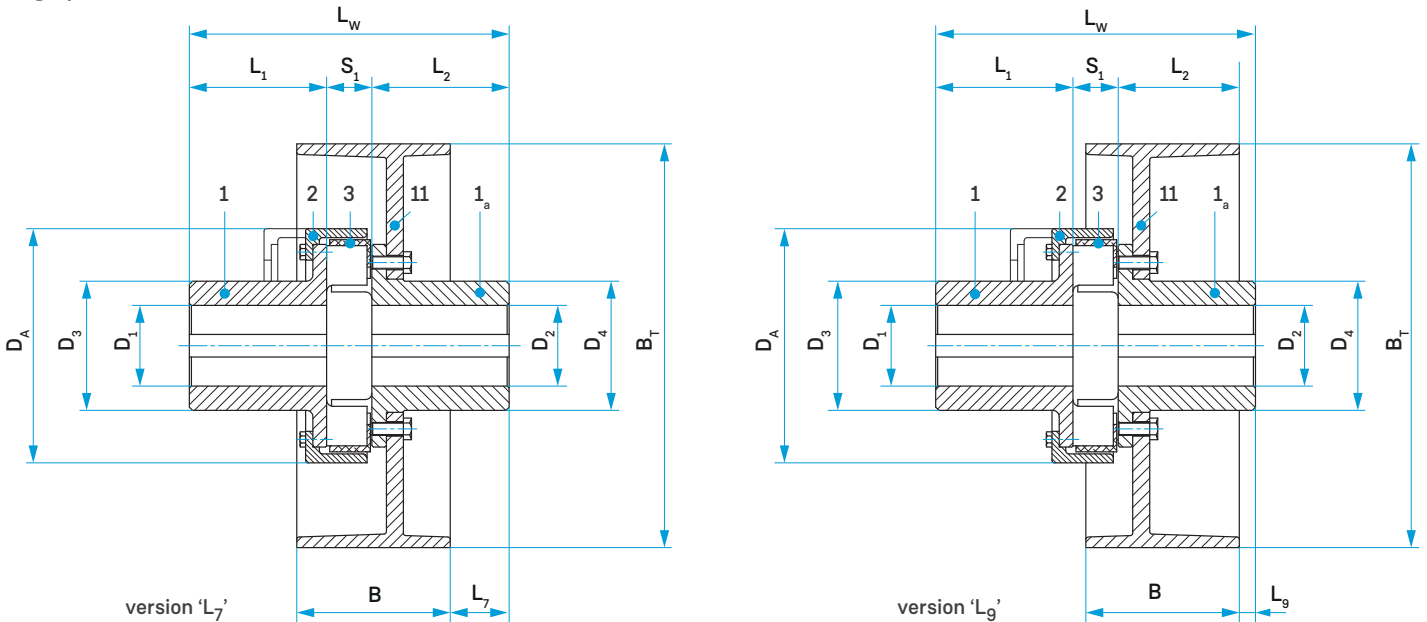

## Coupling details

Coupling size	B <sub>T</sub> [mm]	B [mm]	D <sub>A</sub> [mm]	D <sub>1</sub> /D <sub>2</sub>		D <sub>3</sub> [mm]	D <sub>4</sub> [mm]	L <sub>1</sub>		L <sub>2</sub> [mm]	L <sub>7</sub> [mm]	L <sub>9</sub> [mm]	L <sub>W</sub>		S <sub>1</sub> [mm]	
				pilot bored [mm]	max. [mm]			norm.	long				norm.	long		
MMS 25 WBT 200	200	75	135	unbored/precentered	60	88	87	57	110	110	71	40	189	242	22	
MMS 40 WBT 200	200	75	155		65	96	94	61	110	110	71	40	197	246	26	
MMS 40 WBT 250	250	95	155		65	96	94	61	110	110	56	35	197	246	26	
MMS 63 WBT 250	250	95	174		75	110	110	67	110	110	55	34	207	250	30	
MMS 63 WBT 315	315	118	174		75	110	110	67	110	110	61	5	207	250	30	
MMS 100 WBT 315	315	118	195		80	120	118	75	140	140	87	31	250	315	35	
MMS 160 WBT 315	315	118	221		85	130	130	82	140	140	87	31	263	321	41	
MMS 160 WBT 400	400	150	221		85	130	130	82	140	140	70	11	263	321	41	
MMS 250 WBT 400	400	150	252		100	145	145	89	170	170	98	39	306	387	47	
MMS 250 WBT 500	500	190	252		100	145	145	89	170	170	75	22	306	387	47	
MMS 400 WBT 500	500	190	290		105	160	160	97	170	170	73	20	323	396	56	
MMS 400 WBT 630	630	236	290		105	160	160	97	170	170	41	0	323	396	56	
MMS 630 WBT 500	500	190	330		56	130	200	192	116	210	210	112	59	390	484	64
MMS 630 WBT 630	630	236	330		56	130	200	192	116	210	210	80	39	390	484	64
MMS 630 WBT 710	710	265	330	56	130	200	192	116	210	210	70	20	390	484	64	
MMS 1000 WBT 630	630	236	378	68	150	225	225	140 <sup>1)</sup>	210 <sup>1)</sup>	210 <sup>1)</sup>	67	26	405	475	75	
MMS 1000 WBT 710	710	265	378	68	150	225	225	140 <sup>1)</sup>	210 <sup>1)</sup>	210 <sup>1)</sup>	57	7	405	475	75	
MMS 1600 WBT 710	710	265	432	88	170	255	252	160 <sup>1)</sup>	210 <sup>1)</sup>	210 <sup>1)</sup>	50	0	423	473	85	
MMS 2500 WBT 710	710	265	485	88	180	275	300	250 <sup>1)</sup>	-	250 <sup>1)</sup>	54	4	510	-	110	

1) Figure is not in accordance with actual design

# MULTI MONT SELLA

Type MMS...WBT

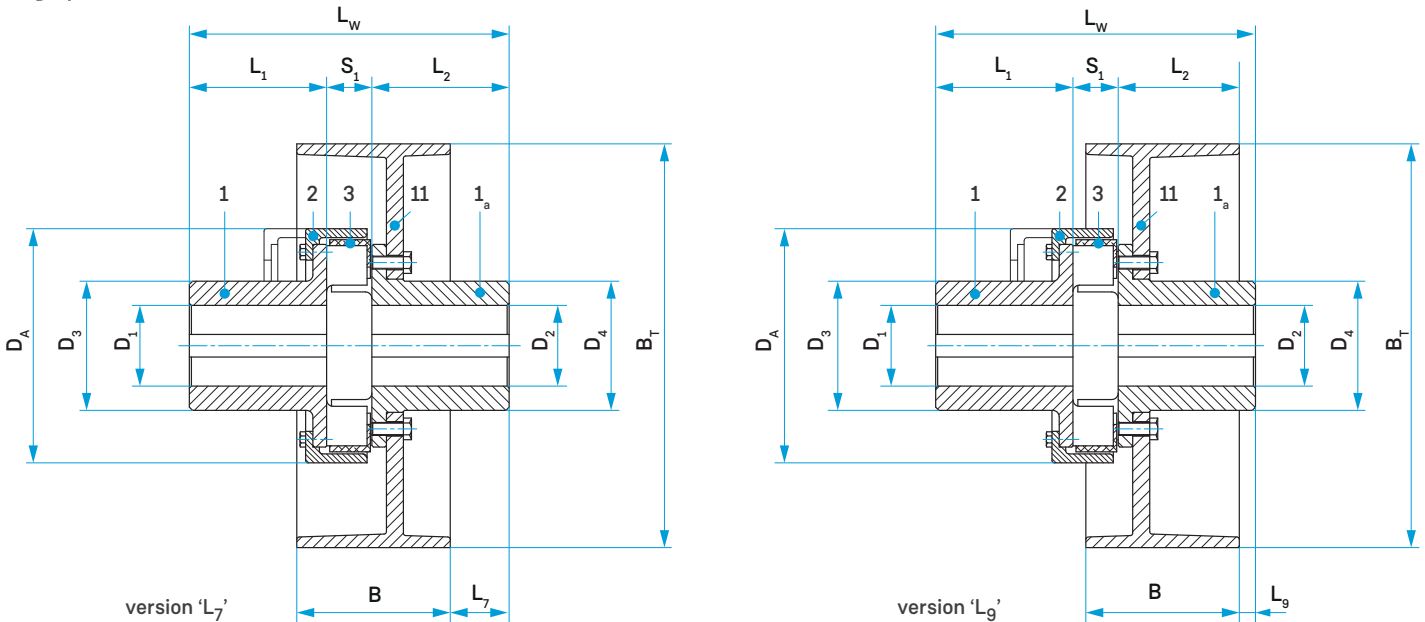

## Coupling details

Coupling size	BT	B	DA	D1/D2		D3	D4	L1		L2	L7	L9	LW		S1	
				pilot bored	max.			norm.	long				norm.	long		
	[in]	[in]	[in]	[in]	[in]	[in]	[in]	[in]	[in]	[in]	[in]	[in]	[in]	[in]	[in]	
MMS 25 WBT 200	7.87	2.95	5.31	unbored/precentered	2.36	3.46	3.43	2.24	4.33	4.33	2.80	1.57	7.44	9.53	0.87	
MMS 40 WBT 200	7.87	2.95	6.10		2.56	3.78	3.70	2.40	4.33	4.33	2.80	1.57	7.76	9.69	1.02	
MMS 40 WBT 250	9.84	3.74	6.10		2.56	3.78	3.70	2.40	4.33	4.33	2.20	1.38	7.76	9.69	1.02	
MMS 63 WBT 250	9.84	3.74	6.85		2.95	4.33	4.33	2.64	4.33	4.33	2.17	1.34	8.15	9.84	1.18	
MMS 63 WBT 315	12.40	4.65	6.85		2.95	4.33	4.33	2.64	4.33	4.33	2.40	0.20	8.15	9.84	1.18	
MMS 100 WBT 315	12.40	4.65	7.68		3.15	4.72	4.65	2.95	5.51	5.51	3.43	1.22	9.84	12.40	1.38	
MMS 160 WBT 315	12.40	4.65	8.70		3.35	5.12	5.12	3.23	5.51	5.51	3.43	1.22	10.35	12.64	1.61	
MMS 160 WBT 400	15.75	5.91	8.70		3.35	5.12	5.12	3.23	5.51	5.51	2.76	0.43	10.35	12.64	1.61	
MMS 250 WBT 400	15.75	5.91	9.92		3.94	5.71	5.71	3.50	6.69	6.69	3.86	1.54	12.05	15.24	1.85	
MMS 250 WBT 500	19.69	7.48	9.92		3.94	5.71	5.71	3.50	6.69	6.69	2.95	0.87	12.05	15.24	1.85	
MMS 400 WBT 500	19.69	7.48	11.42		4.13	6.30	6.30	3.82	6.69	6.69	2.87	0.79	12.72	15.59	2.20	
MMS 400 WBT 630	24.80	9.29	11.42		4.13	6.30	6.30	3.82	6.69	6.69	1.61	0.00	12.72	15.59	2.20	
MMS 630 WBT 500	19.69	7.48	12.99		2.20	5.12	7.87	7.56	4.57	8.27	8.27	4.41	2.32	15.35	19.06	2.52
MMS 630 WBT 630	24.80	9.29	12.99		2.20	5.12	7.87	7.56	4.57	8.27	8.27	3.15	1.54	15.35	19.06	2.52
MMS 630 WBT 710	27.95	10.43	12.99	2.20	5.12	7.87	7.56	4.57	8.27	8.27	2.76	0.79	15.35	19.06	2.52	
MMS 1000 WBT 630	24.80	9.29	14.88	2.68	5.91	8.86	8.86	5.51 <sup>1)</sup>	8.27 <sup>1)</sup>	8.27 <sup>1)</sup>	2.64	1.02	15.94	18.70	2.95	
MMS 1000 WBT 710	27.95	10.43	14.88	2.68	5.91	8.86	8.86	5.51 <sup>1)</sup>	8.27 <sup>1)</sup>	8.27 <sup>1)</sup>	2.24	0.28	15.94	18.70	2.95	
MMS 1600 WBT 710	27.95	10.43	17.01	3.46	6.69	10.04	9.92	6.30 <sup>1)</sup>	8.27 <sup>1)</sup>	8.27 <sup>1)</sup>	1.97	0.00	16.65	18.62	3.35	
MMS 2500 WBT 710	27.95	10.43	19.09	3.46	7.09	10.83	11.81	9.84 <sup>1)</sup>	-	9.84 <sup>1)</sup>	2.13	0.16	20.08	-	4.33	

1) Figure is not in accordance with actual design

# MULTI MONT SELLA

Type MMS...TBT

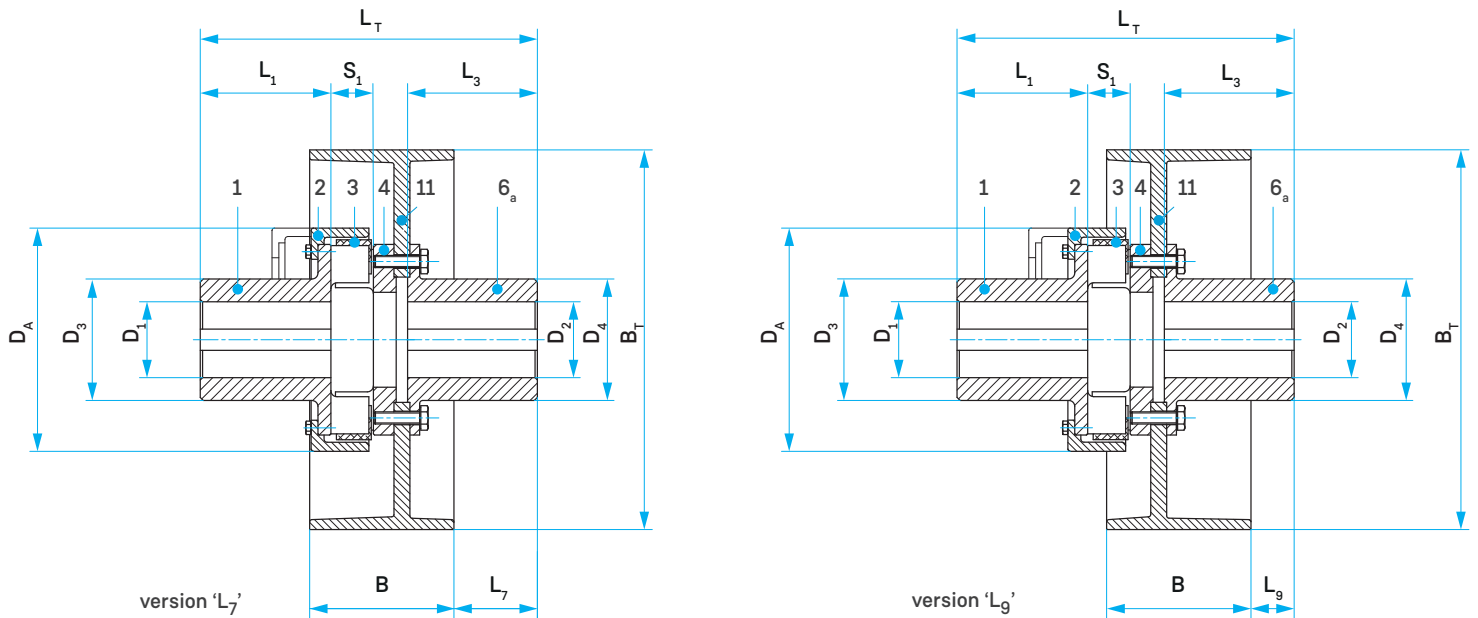

## Coupling details

Coupling size	B <sub>T</sub>	B	D <sub>A</sub>	D <sub>1</sub> /D <sub>2</sub>		D <sub>3</sub>	D <sub>4</sub>	L <sub>1</sub>		L <sub>2</sub>	L <sub>7</sub>	L <sub>9</sub>	L <sub>T</sub>		S <sub>1</sub>
				pilot bored	max.			norm.	long				norm.	long	
	[mm]	[mm]	[mm]	[mm]	[mm]	[mm]	[mm]	[mm]	[mm]	[mm]	[mm]	[mm]	[mm]	[mm]	[mm]
MMS 40 TBT 200	200	75	155	unbored/precentered	65	96	96	61	110	110	94	63	224	273	26
MMS 40 TBT 250	250	95	155		65	96	96	61	110	110	79	58	224	273	26
MMS 63 TBT 250	250	95	174		75	110	110	67	110	110	79	58	237	280	30
MMS 63 TBT 315	315	118	174		75	110	110	67	110	110	85	29	237	280	30
MMS 100 TBT 315	315	118	195		80	120	118	75	140	140	115	59	283	348	35
MMS 160 TBT 315	315	118	221		85	130	130	82	140	140	115	59	299	357	41
MMS 160 TBT 400	400	150	221		85	130	130	82	140	140	103	44	304	362	41
MMS 250 TBT 400	400	150	252		100	145	145	89	170	170	132	73	349	430	47
MMS 250 TBT 500	500	190	252		100	145	145	89	170	170	109	56	349	430	47
MMS 400 TBT 500	500	190	290		105	160	160	97	170	170	109	56	368	441	56
MMS 400 TBT 630	630	236	290		105	160	160	97	170	170	83	42	374	447	56
MMS 630 TBT 500	500	190	330		56	130	200	195	116	210	210	149	96	436	530
MMS 630 TBT 630	630	236	330	56	130	200	195	116	210	210	123	82	441	535	64
MMS 630 TBT 710	710	265	330	56	130	200	195	116	210	210	113	63	441	535	64
MMS 1000 TBT 630	630	236	378	68	150	225	225	140 <sup>1)</sup>	210 <sup>1)</sup>	210 <sup>1)</sup>	123	82	466	536	75
MMS 1000 TBT 710	710	265	378	68	150	225	225	140 <sup>1)</sup>	210 <sup>1)</sup>	210 <sup>1)</sup>	113	63	466	536	75
MMS 1600 TBT 710	710	265	432	88	170	255	255	160 <sup>1)</sup>	210 <sup>1)</sup>	210 <sup>1)</sup>	113	63	490	540	85
MMS 2500 TBT 710	710	265	485	88	180	275	300	250 <sup>1)</sup>	-	250 <sup>1)</sup>	156	106	-	624	110

1) Figure is not in accordance with actual design

# MULTI MONT SELLA

Type MMS...TBT

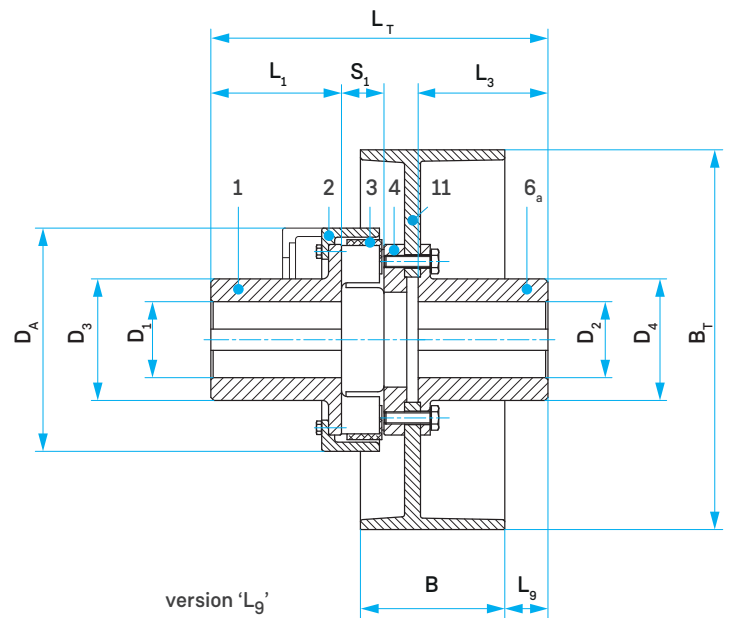
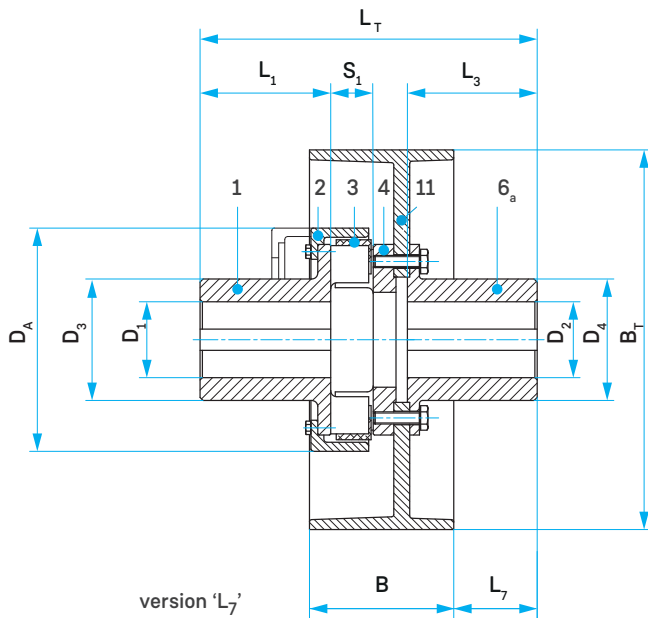

## Coupling details

Coupling size	B <sub>T</sub>	B	D <sub>A</sub>	D <sub>1</sub> /D <sub>2</sub>		D <sub>3</sub>	D <sub>4</sub>	L <sub>1</sub>		L <sub>2</sub>	L <sub>7</sub>	L <sub>9</sub>	L <sub>T</sub>		S <sub>1</sub>	
				pilot bored	max.			norm.	long				norm.	long		
	[in]	[in]	[in]	[in]	[in]	[in]	[in]	[in]	[in]	[in]	[in]	[in]	[in]	[in]	[in]	
MMS 40 TBT 200	7.87	2.95	6.10	unbored/precentered	2.56	3.78	3.78	2.40	4.33	4.33	3.70	2.48	8.82	10.75	1.02	
MMS 40 TBT 250	9.84	3.74	6.10		2.56	3.78	3.78	2.40	4.33	4.33	3.11	2.28	8.82	10.75	1.02	
MMS 63 TBT 250	9.84	3.74	6.85		2.95	4.33	4.33	2.64	4.33	4.33	3.11	2.28	9.33	11.02	1.18	
MMS 63 TBT 315	12.40	4.65	6.85		2.95	4.33	4.33	2.64	4.33	4.33	3.35	1.14	9.33	11.02	1.18	
MMS 100 TBT 315	12.40	4.65	7.68		3.15	4.72	4.65	2.95	5.51	5.51	4.53	2.32	11.14	13.70	1.38	
MMS 160 TBT 315	12.40	4.65	8.70		3.35	5.12	5.12	3.23	5.51	5.51	4.53	2.32	11.77	14.06	1.61	
MMS 160 TBT 400	15.75	5.91	8.70		3.35	5.12	5.12	3.23	5.51	5.51	4.06	1.73	11.97	14.25	1.61	
MMS 250 TBT 400	15.75	5.91	9.92		3.94	5.71	5.71	3.50	6.69	6.69	5.20	2.87	13.74	16.93	1.85	
MMS 250 TBT 500	19.69	7.48	9.92		3.94	5.71	5.71	3.50	6.69	6.69	4.29	2.20	13.74	16.93	1.85	
MMS 400 TBT 500	19.69	7.48	11.42		4.13	6.30	6.30	3.82	6.69	6.69	4.29	2.20	14.49	17.36	2.20	
MMS 400 TBT 630	24.80	9.29	11.42		4.13	6.30	6.30	3.82	6.69	6.69	3.27	1.65	14.72	17.60	2.20	
MMS 630 TBT 500	19.69	7.48	12.99		2.20	5.12	7.87	7.68	4.57	8.27	8.27	5.87	3.78	17.17	20.87	2.52
MMS 630 TBT 630	24.80	9.29	12.99		2.20	5.12	7.87	7.68	4.57	8.27	8.27	4.84	3.23	17.36	21.06	2.52
MMS 630 TBT 710	27.95	10.43	12.99		2.20	5.12	7.87	7.68	4.57	8.27	8.27	4.45	2.48	17.36	21.06	2.52
MMS 1000 TBT 630	24.80	9.29	14.88	2.68	5.91	8.86	8.86	5.51 <sup>1)</sup>	8.27 <sup>1)</sup>	8.27 <sup>1)</sup>	4.84	3.23	18.35	21.10	2.95	
MMS 1000 TBT 710	27.95	10.43	14.88	2.68	5.91	8.86	8.86	5.51 <sup>1)</sup>	8.27 <sup>1)</sup>	8.27 <sup>1)</sup>	4.45	2.48	18.35	21.10	2.95	
MMS 1600 TBT 710	27.95	10.43	17.01	3.46	6.69	10.04	10.04	6.30 <sup>1)</sup>	8.27 <sup>1)</sup>	8.27 <sup>1)</sup>	4.45	2.48	19.29	21.26	3.35	
MMS 2500 TBT 710	27.95	10.43	19.09	3.46	7.09	10.83	11.81	9.84 <sup>1)</sup>	-	9.84 <sup>1)</sup>	6.14	4.17	-	24.57	4.33	

<sup>1)</sup> Figure is not in accordance with actual design

# MULTI MONT SELLA

Type MMS...F1 BT

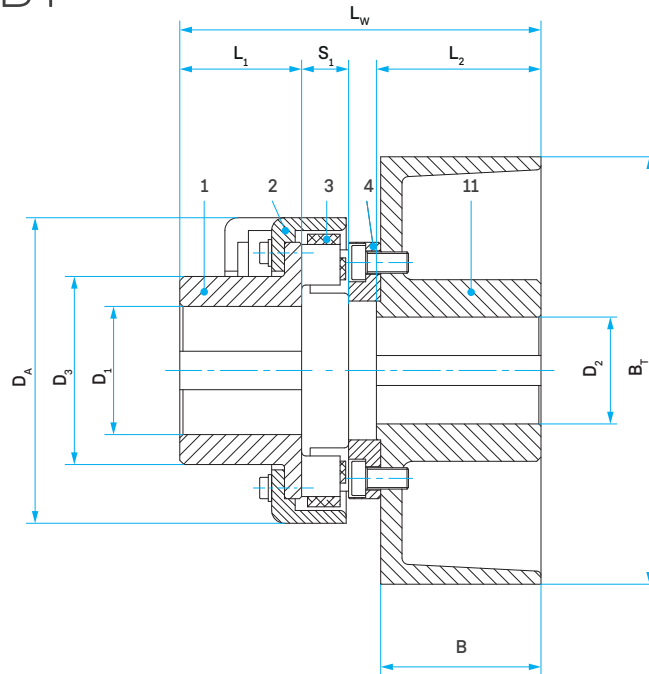

## Coupling details

Coupling size	BT	B	DA	D1	D2		D3	L1		L2	Lw		S1	
					max.	min.		norm.	long		norm.	long		
	[mm]	[mm]	[mm]	pilot bored [mm]	[mm]	[mm]	[mm]	[mm]	[mm]	[mm]	[mm]	[mm]	[mm]	
MMS 16 F1 BT 200	200	75	129	unbored/precentered	50	20	50	78	57	110	77	164	217	19
MMS 25 F1 BT 250	250	95	135		60	25	60	88	57	110	97	193	246	22
MMS 40 F1 BT 200	200	75	155		65	20	50	96	61	110	77	177	226	26
MMS 63 F1 BT 250	250	95	174		75	25	60	110	61	110	97	204	253	30
MMS 100 F1 BT 315	315	118	195		80	30	65	120	61	110	120	235	284	35
MMS 160 F1 BT 250	250	95	221		85	25	60	130	67	110	97	227	270	41
MMS 250 F1 BT 315	315	118	252		100	30	70	145	67	110	120	259	302	47
MMS 400 F1 BT 315	315	118	290		105	30	80	160	75	140	120	277	342	56



# MULTI MONT SELLA

Type MMS...F1 BT

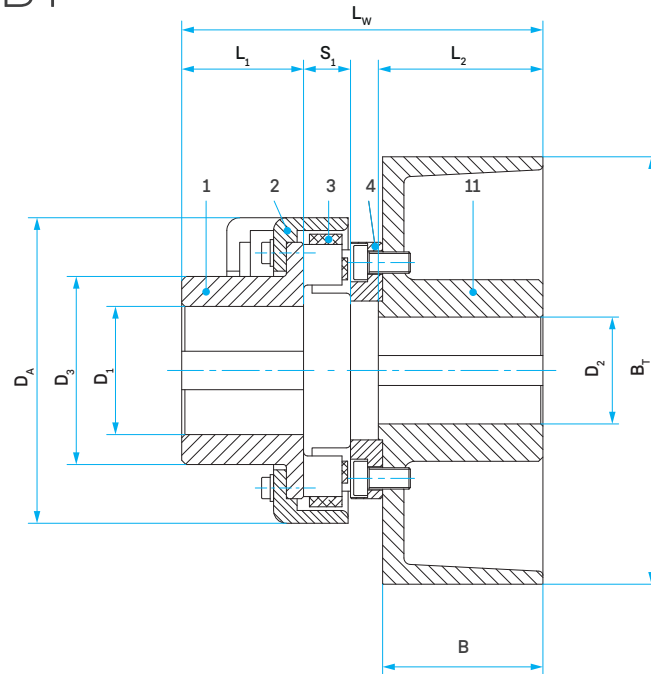

## Coupling details

Coupling size	BT	B	DA	D1	D2		D3	L1		L2	Lw		S1	
					pilot bored	max.		min.	norm.		long	norm.		long
						[in]		[in]						
MMS 16 F1 BT 200	7.87	2.95	5.08	unbored/precentered	1.97	0.79	1.97	3.07	2.24	4.33	3.03	6.46	8.54	0.75
MMS 25 F1 BT 250	9.84	3.74	5.31		2.36	0.98	2.36	3.46	2.24	4.33	3.82	7.60	9.69	0.87
MMS 40 F1 BT 200	7.87	2.95	6.10		2.56	0.79	1.97	3.78	2.40	4.33	3.03	6.97	8.90	1.02
MMS 63 F1 BT 250	9.84	3.74	6.85		2.95	0.98	2.36	4.33	2.40	4.33	3.82	8.03	9.96	1.18
MMS 100 F1 BT 315	12.40	4.65	7.68		3.15	1.18	2.56	4.72	2.40	4.33	4.72	9.25	11.18	1.38
MMS 160 F1 BT 250	9.84	3.74	8.70		3.35	0.98	2.36	5.12	2.64	4.33	3.82	8.94	10.63	1.61
MMS 250 F1 BT 315	12.40	4.65	9.92		3.94	1.18	2.76	5.71	2.64	4.33	4.72	10.20	11.89	1.85
MMS 400 F1 BT 315	12.40	4.65	11.42		4.13	1.18	3.15	6.30	2.95	5.51	4.72	10.91	13.46	2.20

# MULTI MONT SELLA

Shaft-, flange-, and separable flange couplings

## Weights and moments of inertia

Coupling size	MMS-T...W		MMS...W		MMS...F1		MMS...T		Hub with ret. cap	
	$m_{total}$ [kg]	$J_{total}$ [kgm <sup>2</sup> ]	$m_{total}$ [kg]	$J_{total}$ [kgm <sup>2</sup> ]	$m_{total}$ [kg]	$J_{total}$ [kgm <sup>2</sup> ]	$m_{total}$ [kg]	$J_{total}$ [kgm <sup>2</sup> ]	$m_1$ [kg]	$J_1$ [kgm <sup>2</sup> ]
MMS 6.3	-	-	2.4	0.002	1.5	0.0016	-	-	1.2	0.001
MMS 10	-	-	3.4	0.003	1.8	0.003	2.9	0.004	1.3	0.002
MMS 16	-	-	3.0	0.005	2.3	0.004	3.8	0.006	1.6	0.003
MMS 25	3.04	0.006	3.9	0.008	3.1	0.007	5.0	0.010	2.2	0.005
MMS 40	4.86	0.012	5.0	0.013	4.2	0.012	7.1	0.017	2.9	0.008
MMS 63	8.36	0.026	7.5	0.234	6.1	0.021	10.0	0.031	4.1	0.013
MMS 100	16.92	0.067	10.9	0.043	8.8	0.038	14.6	0.058	5.9	0.025
MMS 160	20.83	0.101	15.7	0.079	13.2	0.075	21.0	0.107	8.6	0.046
MMS 250	33.1	0.212	21.2	0.142	18.4	0.138	29.0	0.192	11.7	0.084
MMS 400	51.3	0.422	30.9	0.254	26.9	0.250	41.1	0.342	17.0	0.150
MMS 630	69.5	0.803	57.3	0.709	46.9	0.652	70.8	0.874	33.6	0.467
MMS 1000	98.1	1.477	84.5	1.371	68.0	1.241	106.0	1.69	49.0	0.892
MMS 1600	-	-	121.0	2.556	99.2	2.346	158.0	3.31	69.9	1.662
MMS 2500	-	-	199.0	4.886	117.0	4.75	204.0	6.41	113.0	3.114
MMS 4000	-	-	232.0	7.399	189.0	6.93	350.0	9.46	132.0	4.730
MMS 6300	-	-	343.0	14.38	285.0	13.9	512.0	18.4	195.0	9.271
MMS 10000	-	-	552.0	28.31	435.0	26.0	644.0	33.8	311.0	18.17
MMS 16000	-	-	868.0	61.7	696.0	56.2	1053.0	72.4	489.0	39.0
MMS 25000	-	-	1144.0	99.6	984.0	98.8	1392.0	132.0	641.0	62.5
MMS 40000	-	-	2027.0	274.5	1747.0	271.0	2226.0	314.0	1150.0	176.0
MMS 63000	-	-	3462.0	457.0	2703.0	434.0	4021.0	556.0	1912.0	286.0
MMS 100000	-	-	5661.0	995.0	4370.0	924.0	6464.0	1175.0	3096.0	604.0

**i** The specified values apply to hubs with maximum-sized bore diameters

## METRIC DIMENSIONS

# MULTI MONT SELLA

Brake disc- & brake drum couplings

### Weights and moments of inertia

Coupling size	Hubside parts 1/2/3				BS ∅ [mm]	MMS...WBS parts 1a /10		MMS...TBS parts 4/6a /10		BT ∅ [mm]	MMS...WBT parts 1a /11		MMS...TBT parts 4/6a /11		MMS...F1 BT parts 4 /11			
	L <sub>1</sub> normal		L <sub>1</sub> long			m <sub>2</sub> [kg]	J <sub>2</sub> [kgm <sup>2</sup> ]	m <sub>2</sub> [kg]	J <sub>2</sub> [kgm <sup>2</sup> ]		m <sub>2</sub> [kg]	J <sub>2</sub> [kgm <sup>2</sup> ]	m <sub>2</sub> [kg]	J <sub>2</sub> [kgm <sup>2</sup> ]	m <sub>2</sub> [kg]	J <sub>2</sub> [kgm <sup>2</sup> ]	m <sub>2</sub> [kg]	J <sub>2</sub> [kgm <sup>2</sup> ]
	m <sub>1</sub> [kg]	J <sub>1</sub> [kgm <sup>2</sup> ]	m <sub>1</sub> [kg]	J <sub>1</sub> [kgm <sup>2</sup> ]														
MMS 16	1.7	0.0023	-	-	-	-	-	-	-	200	-	-	-	-	7.3	0.031		
MMS 25	2.2	0.004	3.3	0.006	-	-	-	-	-	200	9.0	0,048	-	-	7.4	0.060		
MMS 25	2.2	0.004	3.3	0.006	-	-	-	-	-	250	-	-	-	-	12.6	0.121		
MMS 40	3.0	0.006	4.0	0.008	-	-	-	-	-	200	9.5	0.050	10.9	0.054	7.7	0.035		
MMS 40	3.0	0.006	4.0	0.008	-	-	-	-	-	250	14.7	0.135	16.1	0.139	12.9	0.096		
MMS 40	3.0	0.006	4.0	0.008	315	20.4	0.232	21.8	0.236	315	-	-	-	-	26.0	0.315		
MMS 63	4.1	0.013	5.5	0.016	355	26.2	0.376	27.9	0.382	250	15.9	0.141	17.7	0.147	13.6	0.100		
MMS 63	4.1	0.013	5.5	0.016	400	32.5	0.601	34.2	0.607	315	25.0	0.387	26.8	0.393	26.8	0.318		
MMS 100	5.9	0.025	8.8	0.033	400	35.3	0.613	38.4	0.626	315	28.0	0.400	31.1	0.413	27.9	0.326		
MMS 100	5.9	0.025	8.8	0.033	450	43.1	0.969	46.2	0.982	-	-	-	-	-	-	-		
MMS 100	5.9	0.025	8.8	0.033	500	51.9	1.466	55.0	1.479	-	-	-	-	-	-	-		
MMS 160	8.6	0.046	11.5	0.055	450	45.0	0.984	49.9	1.013	315	30.0	0.415	34.9	0.444	-	-		
MMS 160	8.6	0.046	11.5	0.055	500	53.8	1.481	58.7	1.510	400	39.3	0.868	44.4	0.897	-	-		
MMS 160	8.6	0.016	11.5	0.055	560	65.5	2.309	70.4	2.338	-	-	-	-	-	-	-		
MMS 250	15.1	0.116	19.4	0.135	500	57.5	1.515	64.3	1.566	400	43.5	0.902	50.3	0.953	-	-		
MMS 250	15.1	0.116	19.4	0.135	560	69.3	2.343	76.1	2.394	500	64.0	2.354	70.8	2.405	-	-		
MMS 250	15.1	0.116	19.4	0.135	630	84.7	3.711	91.5	3.762	-	-	-	-	-	-	-		
MMS 400	22.6	0.242	28.8	0.274	560	74.3	2.396	83.6	2.485	500	69.3	2.409	78.6	2.498	-	-		
MMS 400	22.6	0.242	28.8	0.274	630	89.7	3.764	99.0	3.853	630	112.8	6.704	122.1	6.884	-	-		
MMS 400	22.6	0.242	28.8	0.274	710	109.8	5.999	119.1	6.088	-	-	-	-	-	-	-		
MMS 630	36.0	0.484	44.8	0.549	630	101.4	3.929	115.2	4.102	500	81.6	2.578	95.4	2.751	-	-		
MMS 630	36.0	0.484	44.8	0.549	710	121.5	6.166	135.3	6.339	630	124.8	6.869	138.6	7.042	-	-		
MMS 630	36.0	0.484	44.8	0.549	800	146.6	9.759	160.4	9.932	710	160.7	12.02	174.5	12.19	-	-		
MMS 1000	51.9	0.911	61.8	1.014	710	132.6	6.428	149.4	6.705	630	136.1	7.130	152.9	7.407	-	-		
MMS 1000	51.9	0.911	61.8	1.014	800	157.7	10.02	174.5	10.30	710	172.1	12.28	188.9	12.56	-	-		
MMS 1000	51.9	0.911	61.8	1.014	1000	282.7	31.35	299.5	31.62	-	-	-	-	-	-	-		
MMS 1600	75.4	1.742	82.7	1.851	800	170.2	10.45	196.6	10.98	710	184.6	12.71	211.0	13.24	-	-		
MMS 1600	75.4	1.742	82.7	1.851	1000	294.4	31.77	320.8	32.30	-	-	-	-	-	-	-		
MMS 2500	113.0	3.110	-	-	1000	309.0	32.30	365.0	33.80	710	201.0	13.00	256.0	14.50	-	-		

# MULTI MONT SELLA

Shaft-, flange-, and separable flange couplings

## Weights and moments of inertia

Coupling size	MMS-T...W		MMS...W		MMS...F1		MMS...T		Hub with ret. cap	
	$m_{total}$ [lb]	$J_{total}$ [lb-in <sup>2</sup> ]	$m_{total}$ [lb]	$J_{total}$ [lb-in <sup>2</sup> ]	$m_{total}$ [lb]	$J_{total}$ [lb-in <sup>2</sup> ]	$m_{total}$ [lb]	$J_{total}$ [lb-in <sup>2</sup> ]	$m_1$ [lb]	$J_1$ [lb-in <sup>2</sup> ]
MMS 6.3	-	-	4.2	5.5	2.9	4.1	-	-	2.7	3.4
MMS 10	-	-	5.3	8.9	4.0	6.8	6.2	9.6	2.9	6.8
MMS 16	-	-	6.8	14.4	5.3	13.7	8.2	18.8	3.5	10.3
MMS 25	6.7	20.8	9.3	23.9	7.3	20.5	10.8	27.3	4.9	17.1
MMS 40	10.7	41.0	12.6	37.6	9.9	34.2	15.7	51.3	6.4	27.3
MMS 63	18.5	88.9	18.1	78.6	14.6	71.8	22.0	99.1	9.1	44.4
MMS 100	37.3	230.3	25.8	150.4	21.2	140.1	31.7	187.9	13.0	85.4
MMS 160	46.0	344.1	36.6	266.5	30.6	259.7	45.2	348.6	19.0	157.2
MMS 250	73.1	724.4	51.4	478.4	43.4	471.6	63.7	621.9	25.8	287.0
MMS 400	113.2	1442.1	71.7	874.8	62.4	878.2	89.1	1131.1	37.5	512.6
MMS 630	153.4	2744.0	136.7	2518.5	113.1	2378.4	161.2	2993.4	74.2	1595.8
MMS 1000	216.5	5023.2	199.5	4828.5	160.9	4442.3	235.9	5706.7	108.1	3048.1
MMS 1600	-	-	288.8	9188.8	235.9	8498.5	339.5	10911.0	154.3	5679.3
MMS 2500	-	-	473.0	18320.5	389.4	17807.8	602.8	24199.4	249.4	10641.1
MMS 4000	-	-	512.0	25283.7	417.1	23681.0	772.5	32326.5	291.3	16163.2
MMS 6300	-	-	757.0	49138.9	629.0	47498.7	1130.0	62876.0	430.4	31680.6
MMS 10000	-	-	1218.3	96740.1	960.1	88846.5	1421.3	115500.4	686.4	62090.0
MMS 16000	-	-	1915.7	210839.5	1536.1	192045.1	2324.0	274703.3	1079.2	133269.7
MMS 25000	-	-	2524.8	340350.1	2171.7	337616.6	3072.1	451066.7	1414.7	213573.2
MMS 40000	-	-	4473.6	936305.1	3855.6	926053.6	4912.8	1072992.0	2538.1	601422.3
MMS 63000	-	-	7640.6	1561647.6	5965.5	1483052.6	8874.4	1899947.6	4219.8	977311.2
MMS 100000	-	-	12493.8	3400086.0	9644.6	3157466.8	14266.1	4015177.0	6832.9	2063971.8

**i** The specified values apply to hubs with maximum-sized bore diameters

## INCH DIMENSIONS

# MULTI MONT SELLA

Brake disc- & brake drum couplings

### Weights and moments of inertia

Coupling size	Hubside parts 1/2/3				BS ∅ [mm]	MMS...WBS parts 1a /10		MMS...TBS parts 4/6a /10		BT ∅ [mm]	MMS...WBT parts 1a /11		MMS...TBT parts 4/6a /11		MMS...F1 BT parts 4 /11	
	L <sub>1</sub> normal		L <sub>1</sub> long			m <sub>2</sub> [lb]	J <sub>2</sub> [lb-in <sup>2</sup> ]	m <sub>2</sub> [lb]	J <sub>2</sub> [lb-in <sup>2</sup> ]		m <sub>2</sub> [lb]	J <sub>2</sub> [lb-in <sup>2</sup> ]	m <sub>2</sub> [lb]	J <sub>2</sub> [lb-in <sup>2</sup> ]	m <sub>2</sub> [lb]	J <sub>2</sub> [lb-in <sup>2</sup> ]
	m <sub>1</sub> [lb]	J <sub>1</sub> [lb-in <sup>2</sup> ]	m <sub>1</sub> [lb]	J <sub>1</sub> [lb-in <sup>2</sup> ]												
MMS 16	3.7	7.9	-	-	-	-	-	-	-	200	-	-	-	-	16.1	105.9
MMS 25	4.9	13.7	7.3	20.5	-	-	-	-	-	200	19.8	164.0	-	-	16.3	205.0
MMS 25	4.9	13.7	7.3	20.5	-	-	-	-	-	250	-	-	-	-	27.8	413.5
MMS 40	6.6	20.5	8.8	27.3	-	-	-	-	-	200	20.9	170.9	24.0	184.5	17.0	119.6
MMS 40	6.6	20.5	8.8	27.3	-	-	-	-	-	250	32.4	461.3	35.5	475.0	28.4	328.0
MMS 40	6.6	20.5	8.8	27.3	315	45.0	792.8	48.1	806.5	315	-	-	-	-	57.3	1076.4
MMS 63	9.1	44.4	12.1	54.7	355	57.8	1284.9	61.5	1305.4	250	35.1	481.8	39.0	502.3	30.0	341.7
MMS 63	9.1	44.4	12.1	54.7	400	71.7	2053.7	75.4	2074.2	315	55.1	1322.4	59.1	1342.9	59.1	1086.7
MMS 100	13.0	85.4	19.4	112.8	400	77.8	2094.7	84.7	2139.1	315	61.7	1366.9	68.6	1411.3	61.5	1114.0
MMS 100	13.0	85.4	19.4	112.8	450	95.0	3311.2	101.9	3355.7	-	-	-	-	-	-	-
MMS 100	13.0	85.4	19.4	112.8	500	114.4	5009.6	121.3	5054.0	-	-	-	-	-	-	-
MMS 160	19.0	157.2	25.4	187.9	450	99.2	3362.5	110.0	3461.6	315	66.1	1418.1	76.9	1517.2	-	-
MMS 160	19.0	157.2	25.4	187.9	500	118.6	5060.8	129.4	5159.9	400	86.6	2966.1	97.9	3065.2	-	-
MMS 160	19.0	54.7	25.4	187.9	560	144.4	7890.2	155.2	7989.3	-	-	-	-	-	-	-
MMS 250	33.3	396.4	42.8	461.3	500	126.8	5177.0	141.8	5351.3	400	95.9	3082.3	110.9	3256.6	-	-
MMS 250	33.3	396.4	42.8	461.3	560	152.8	8006.4	167.8	8180.7	500	141.1	8044.0	156.1	8218.3	-	-
MMS 250	33.3	396.4	42.8	461.3	630	186.7	12681.1	201.7	12855.4	-	-	-	-	-	-	-
MMS 400	49.8	827.0	63.5	936.3	560	163.8	8187.5	184.3	8491.7	500	152.8	8232.0	173.3	8536.1	-	-
MMS 400	49.8	827.0	63.5	936.3	630	197.8	12862.2	218.3	13166.4	630	248.7	22908.7	269.2	23523.8	-	-
MMS 400	49.8	827.0	63.5	936.3	710	242.1	20499.6	262.6	20803.7	-	-	-	-	-	-	-
MMS 630	79.4	1653.9	98.8	1876.0	630	223.5	13426.1	254.0	14017.2	500	179.9	8809.5	210.3	9400.6	-	-
MMS 630	79.4	1653.9	98.8	1876.0	710	267.9	21070.3	298.3	21661.5	630	275.1	23472.6	305.6	24063.7	-	-
MMS 630	79.4	1653.9	98.8	1876.0	800	323.2	33348.2	353.6	33939.4	710	354.3	41067.6	384.7	41658.7	-	-
MMS 1000	114.4	3113.0	136.2	3465.0	710	292.3	21965.6	329.4	22912.1	630	300.0	24364.4	337.1	25311.0	-	-
MMS 1000	114.4	3113.0	136.2	3465.0	800	347.7	34243.5	384.7	35190.0	710	379.4	41980.0	416.5	42926.5	-	-
MMS 1000	114.4	3113.0	136.2	3465.0	1000	623.2	107111.3	660.3	108057.8	-	-	-	-	-	-	-
MMS 1600	166.2	5952.7	182.3	6325.2	800	375.2	35716.3	433.4	37527.4	710	407.0	43418.6	465.2	45229.7	-	-
MMS 1600	166.2	5952.7	182.3	6325.2	1000	649.0	108549.9	707.2	110361.0	-	-	-	-	-	-	-
MMS 2500	249.4	10627.4	-	-	1000	682.0	110374.7	805.6	115500.4	710	443.6	44423.2	565.0	49549.0	-	-

# MULTI MONT SELLA

## Data Required for Coupling Size Selection

### General system details

1. Place of use/environmental conditions (e.g. mining; offshore; container): \_\_\_\_\_
2. Load (uniform/medium/heavy): \_\_\_\_\_
3. Starting frequency per hour: \_\_\_\_\_ [-]
4. Ambient temperature at the coupling: \_\_\_\_\_ [°C]
5. Shaft displacement: \_\_\_\_\_  $\Delta K_A$ : \_\_\_\_\_  $\Delta K_r$ : \_\_\_\_\_  $\Delta K_W$ : \_\_\_\_\_

### Balancing without keyway:

1. Balancing quality according to DIN ISO 21940 (standard quality G 16): G \_\_\_\_\_
2. Balancing speed (standard speed 1500 min<sup>-1</sup>): \_\_\_\_\_ [min<sup>-1</sup>]
3. Annotations: \_\_\_\_\_  
\_\_\_\_\_

### Drive side

1. Prime mover (e.g. electric hydraulic motor): \_\_\_\_\_
2. Nominal power (nominal operation): \_\_\_\_\_ [kW]
3. Speed (nominal speed): \_\_\_\_\_ [min<sup>-1</sup>]
4. max. starting torque (e.g. tilting torque): \_\_\_\_\_ [Nm]
5. Variable speed operation of: \_\_\_\_\_ from \_\_\_\_\_ [min<sup>-1</sup>]

### Drive side

1. Type of application (e.g. generator, crane systems): \_\_\_\_\_
2. Nominal power: \_\_\_\_\_ [kW]
3. max. starting/shock torque: \_\_\_\_\_ [Nm]

### Shaft dimensions

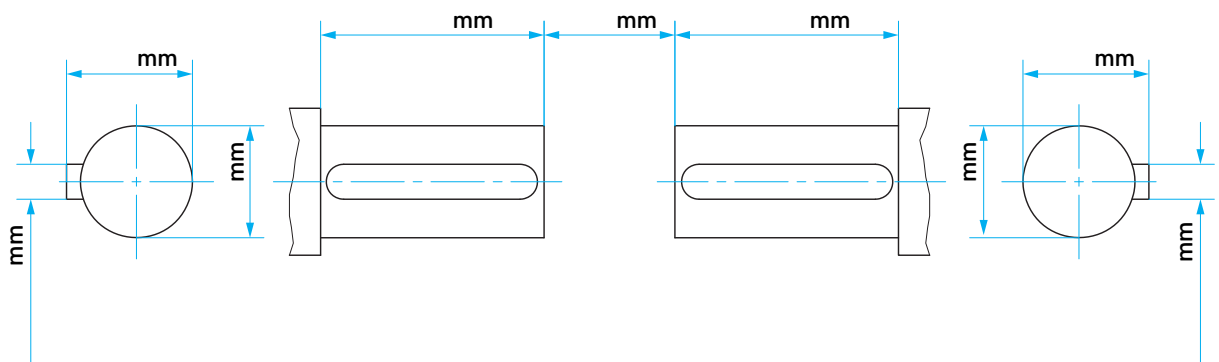

### Further coupling design specifications (e.g. with brake drum/brake disc/Doku/ATEX):

---



---



---



---



---













## MULTI MONT SELLA

SIMPLY **POWERFUL.**

### Industrial solutions:

-  Power generation
-  Mobile applications
-  Test benches
-  Pumps & compressors
-  Industry
-  Ship & port engineering

### Stammhaus:

Dipl.-Ing. Herwarth Reich GmbH  
Vierhausstraße 53 · 44807 Bochum

 +49 234 959 16 - 0

 [mail@reich-kupplungen.com](mailto:mail@reich-kupplungen.com)

 [www.reich-kupplungen.com](http://www.reich-kupplungen.com)

Reich USA Corporation  
300 Route 17 South - Suite H  
Mahwah, New Jersey 07430 USA

 201 68 49 40-0

 [sales@reichusa.com](mailto:sales@reichusa.com)

 [www.reichusa.com](http://www.reichusa.com)

### Copyright ISO 16016 to be observed:

The reproduction, distribution and utilization of this document as well as the communication of its contents to others without explicit authorization is prohibited. Offenders will be held liable for the payment of damages. All rights reserved in the event of the grant of a patent, utility model or design. © REICH - Dipl.- Ing. Herwarth Reich GmbH

### March 2020 edition

The present MULTI MONT SELLA catalog edition renders parts of the previous MULTI MONT SELLA catalogs obsolete. All dimensions in millimeters. We reserve the right to change dimensions and/or design without prior notice. Texts and illustrations, dimensional and performance data have been compiled with the utmost care. There is no guarantee, however, that the information is accurate; in particular, there is no guarantee that products will match the illustrations in terms of technology, color, shape and configuration or that the products will correspond to the proportions of the illustrations. We also reserve the right to make changes due to printing errors or mistakes.

